



# **ADIKAVI NANNAYA UNIVERSITY**

## **AKNU COLLEGE OF ENGINEERING RAJAMAHENDRAVARAM**

**DEPARTMENT OF SCIENCE & HUMANITIES**

### **I B.Tech**

**(Electronics and Instrumentation Engineering)**

**SYLLABUS & MODEL QUESTION PAPERS**

**(w.e.f. AY 2023-24 - as per R23 Regulations)**

**BOARD OF STUDIES**

**AKNU COLLEGE OF ENGINEERING**

**ADIKAVI NANNAYA UNIVERSITY COLLEGE OF ENGINEERING  
DEPARTMENT OF SCIENCE & HUMANITIES**



COURSE STRUCTURE FOR AY 2023-24

**B.Tech. – I Year I Semester (EIE)**

S.No	Category	Title	L/D	T	P	Credits
1	R23HS01	Communicative English	2	0	0	2
2	R23BS01	Linear Algebra & Calculus	3	0	0	3
3	R23BS05	Chemistry	3	0	0	3
4	R23ES01	Basic Civil and Mechanical Engineering	3	0	0	3
5	R23ES07	Introduction to Programming	3	0	0	3
6	R23HS01-P	Communicative English Lab	0	0	2	1
7	R23BS05-P	Chemistry Lab	0	0	2	1
8	R23ES02-P	Engineering Workshop	0	0	3	1.5
9	R23ES07-P	Computer Programming Lab	0	0	3	1.5
10	R23MC01	Health and Wellness, Yoga and Sports	-	-	1	0.5
<b>Total</b>			<b>14</b>	<b>00</b>	<b>11</b>	<b>19.5</b>

**B.Tech. – I Year II Semester (EIE)**

S.No.	Category	Title	L/D	T	P	Credits
1	R23BS02	Differential Equations & Vector Calculus	3	0	0	3
2	R23BS03	Engineering Physics	3	0	0	3
3	R23ES03	Engineering Graphics	3	0	0	3
4	R23ES04	Basic Electrical and Electronics Engineering	1	0	4	3
5	R23PC04	Network Analysis	3	0	0	3
6	R23BS03-P	Engineering Physics Lab	0	0	2	1
7	R23ES04-P	Electrical and Electronics Engineering Workshop	0	0	2	1
8	R23ES06-P	IT Workshop	0	0	3	1.5
9	R23PC04-P	Network Analysis and Simulation Lab	0	0	3	1.5
10	R23MC02	NSS/NCC/Scouts & Guides/Community Service	-	-	1	0.5
<b>Total</b>			<b>13</b>	<b>00</b>	<b>15</b>	<b>20.5</b>



**B.Tech. – I Year I Semester (EIE)**

S.No	Category	Title	L/D	T	P	Credits
1	R23HS01	Communicative English	2	0	0	2
2	R23BS01	Linear Algebra & Calculus	3	0	0	3
3	R23BS05	Chemistry	3	0	0	3
4	R23ES01	Basic Civil and Mechanical Engineering	3	0	0	3
5	R23ES07	Introduction to Programming	3	0	0	3
6	R23HS01-P	Communicative English Lab	0	0	2	1
7	R23BS05-P	Chemistry Lab	0	0	2	1
8	R23ES02-P	Engineering Workshop	0	0	3	1.5
9	R23ES07-P	Computer Programming Lab	0	0	3	1.5
10	R23MC01	Health and Wellness, Yoga and Sports	-	-	1	0.5
<b>Total</b>			<b>14</b>	<b>00</b>	<b>11</b>	<b>19.5</b>



**R23HS01**

L	T	P	C
2	0	0	2

**COMMUNICATIVE ENGLISH**  
(Common to All Branches of Engineering)

**Course Objectives:**

The main objective of introducing this course, *Communicative English*, is to facilitate effective listening, Reading, Speaking and Writing skills among the students. It enhances the same in their comprehending abilities, oral presentations, reporting useful information and providing knowledge of grammatical structures and vocabulary. This course helps the students to make them effective in speaking and writing skills and to make them industry ready.

**Course Outcomes:**

- CO1: Understand the context, topic, and pieces of specific information from social or Transactional dialogues.
- CO2: Apply grammatical structures to formulate sentences and correct word forms.
- CO3: Analyze discourse markers to speak clearly on a specific topic in informal discussions.
- CO4: Evaluate reading / listening texts and to write summaries based on global comprehension of these texts.
- CO5: Create a coherent paragraph, essay, and resume.

**UNIT I**

- Lesson:** HUMAN VALUES: Gift of Magi (Short Story)
- Listening:** Identifying the topic, the context and specific pieces of information by listening to short audio texts and answering a series of questions.
- Speaking:** Asking and answering general questions on familiar topics such as home, family, work, studies and interests; introducing oneself and others.
- Reading:** Skimming to get the main idea of a text; scanning to look for specific pieces of information.
- Writing:** Mechanics of Writing-Capitalization, Spellings, Punctuation-Parts of Sentences.
- Grammar:** Parts of Speech, Basic Sentence Structures-forming questions
- Vocabulary:** Synonyms, Antonyms, Affixes (Prefixes/Suffixes), Root words.

**UNIT II**

- Lesson:** NATURE: The Brook by Alfred Tennyson (Poem)
- Listening:** Answering a series of questions about main ideas and supporting ideas after listening to audio texts.
- Speaking:** Discussion in pairs/small groups on specific topics followed by short structure talks.
- Reading:** Identifying sequence of ideas; recognizing verbal techniques that help to link the ideas in a paragraph together.
- Writing:** Structure of a paragraph - Paragraph writing (specific topics)
- Grammar:** Cohesive devices - linkers, use of articles and zero article; prepositions.
- Vocabulary:** Homonyms, Homophones, Homographs.

**UNIT III**

- Lesson:** BIOGRAPHY: Elon Musk
- Listening:** Listening for global comprehension and summarizing what is listened to.
- Speaking:** Discussing specific topics in pairs or small groups and reporting what is discussed
- Reading:** Reading a text in detail by making basic inferences -recognizing and interpreting specific context clues; strategies to use text clues for comprehension.
- Writing:** Summarizing, Note-making, paraphrasing
- Grammar:** Verbs - tenses; subject-verb agreement; Compound words, Collocations



**Vocabulary:** Compound words, Collocations

#### UNIT IV

- Lesson:** INSPIRATION: The Toys of Peace by Saki  
**Listening:** Making predictions while listening to conversations/ transactional dialogues without video; listening with video.  
**Speaking:** Role plays for practice of conversational English in academic contexts (formal and informal) - asking for and giving information/directions.  
**Reading:** Studying the use of graphic elements in texts to convey information, reveal trends/patterns/relationships, communicate processes or display complicated data.  
**Writing:** Letter Writing: Official Letters, Resumes  
**Grammar:** Reporting verbs, Direct & Indirect speech, Active & Passive Voice  
**Vocabulary:** Words often confused, Jargons

#### UNIT V

- Lesson:** MOTIVATION: The Power of Intrapersonal Communication (An Essay)  
**Listening:** Identifying key terms, understanding concepts and answering a series of relevant questions that test comprehension.  
**Speaking:** Formal oral presentations on topics from academic contexts  
**Reading:** Reading comprehension.  
**Writing:** Writing structured essays on specific topics.  
**Grammar:** Editing short texts –identifying and correcting common errors in grammar and usage (articles, prepositions, tenses, subject verb agreement)  
**Vocabulary:** Technical Jargons

Textbooks:

1. Pathfinder: Communicative English for Undergraduate Students, 1<sup>st</sup> Edition, Orient Black Swan, 2023 (Units 1,2 & 3)
2. Empowering with Language by Cengage Publications, 2023 (Units 4 & 5)

Reference Books:

1. Dubey, Sham Ji & Co. English for Engineers, Vikas Publishers, 2020
2. Bailey, Stephen. Academic writing: A Handbook for International Students. Routledge, 2014.
3. Murphy, Raymond. English Grammar in Use, Fourth Edition, Cambridge University Press, 2019.
4. Lewis, Norman. Word Power Made Easy- The Complete Handbook for Building a Superior Vocabulary. Anchor, 2014.

**Web Resources:**

GRAMMAR:

- [www.bbc.co.uk/learningenglish](http://www.bbc.co.uk/learningenglish)  
<https://dictionary.cambridge.org/grammar/british-grammar/>  
[www.eslpod.com/index.html](http://www.eslpod.com/index.html)  
<https://www.learngrammar.net/>  
<https://english4today.com/english-grammar-online-with-quizzes/>  
<https://www.talkenglish.com/grammar/grammar.aspx>

VOCABULARY

- <https://www.youtube.com/c/DailyVideoVocabulary/videos>  
[https://www.youtube.com/channel/UC4cmBAit8i\\_NJZE8qK8sfpA](https://www.youtube.com/channel/UC4cmBAit8i_NJZE8qK8sfpA)



**R23BS01**

L	T	P	C
3	0	0	3

**LINEAR ALGEBRA & CALCULUS**  
(Common to All Branches of Engineering)

**Course Objectives:**

To equip the students with standard concepts and tools at an intermediate to advanced level mathematics to develop the confidence and ability among the students to handle various real-world problems and their applications.

**Course Outcomes:** At the end of the course, the student will be able to

CO1: Find the Rank of a matrix and solve the system of equations.

CO2: Find the inverse and power of a matrix by using Cayley-Hamilton theorem and reduce quadratic form to Canonical form.

CO3: Understanding the importance of Mean value theorems and expand the given function as a power series.

CO4: Familiarize with functions of several variables which is useful in optimization.

CO5: Familiarize with double and triple integrals of functions of several variables in two dimensions using Cartesian and polar coordinates and in three dimensions using cylindrical and spherical coordinates.

**UNIT I: Matrices**

Rank of a matrix by echelon form, normal form and normal form of the type PAQ. Inverse of Non-singular matrices by Gauss-Jordan method, System of linear equations: Solving system of Homogeneous and Non-Homogeneous equations by Gauss elimination, Gauss – Jordan and Gauss Seidel Iteration Methods, Consistency and Inconsistency of linear system equations.

**UNIT II: Eigenvalues, Eigenvectors and Orthogonal Transformation**

Eigenvalues, Eigenvectors and their properties (without proof), Diagonalization of a matrix, Cayley-Hamilton Theorem (without proof), finding inverse and power of a matrix by Cayley-Hamilton Theorem, Quadratic forms and Nature of the Quadratic Forms, Reduction of Quadratic form to canonical forms by Orthogonal Transformation.

**UNIT III: Calculus**

Mean Value Theorems: Rolle’s Theorem, Lagrange’s mean value theorem, Cauchy’s mean value theorem, Taylor’s and Maclaurin theorems with remainders (without proof), and related Problems.

**UNIT IV: Partial differentiation and Applications (Multi variable calculus)**

Functions of several variables: Continuity and Differentiability, Partial derivatives, Homogeneous functions, Euler’s theorem, total derivatives, chain rule, Taylor’s and Maclaurin’s series expansion of functions of two variables. Jacobians, Functional dependence, maxima and minima of functions of two variables, method of Lagrange multipliers.



### **UNIT V: Multiple Integrals (Multi variable Calculus)**

Double integrals, triple integrals, change of order of integration, change of variables to polar, cylindrical and spherical coordinates. Finding areas (by double integrals) and volumes (by double integrals and triple integrals).

#### **Textbooks:**

1. Higher Engineering Mathematics, B. S. Grewal, Khanna Publishers, 2017, 44<sup>th</sup> Edition.
2. Higher Engineering Mathematics, B.V.Ramana, Mc Graw Hill Education(India) Private Limited 19<sup>th</sup> edition.
3. Engineering Matematics-III, Dr. G.Venkata Rao and Dr.A.V Paparao,Cengage Publication 2017.

#### **Reference Books:**

1. Thomas Calculus, George B. Thomas, Maurice D. Weir and Joel Hass, Pearson Publishers, 2018, 14<sup>th</sup> Edition.
2. Advanced Engineering Mathematics, R. K. Jain and S. R. K. Iyengar, Alpha Science International Ltd., 2021 5<sup>th</sup> Edition (9<sup>th</sup> reprint).
3. Advanced Modern Engineering Mathematics, Glyn James, Pearson publishers, 2018, 5<sup>th</sup> Edition.
4. Advanced Engineering Mathematics, Micheael Greenberg, Pearson publishers, 9<sup>th</sup> edition
5. Higher Engineering Mathematics, H. K Das, Er. Rajnish Verma, S. Chand Publications,2014, Third Edition (Reprint 2021)



**R23BS05**

L	T	P	C
3	0	0	3

**CHEMISTRY**

(Common to EEE, ECE, CSE, IT) & allied branches)

**Course Objectives:**

- To familiarize engineering chemistry and its applications
- To train the students on the principles and applications of electrochemistry and polymers
- To introduce instrumental methods, molecular machines and switches.

**Course Outcomes:** At the end of the course, the students will be able to:

**CO1:** Compare the materials of construction for battery and electrochemical sensors.

**CO2:** Explain the preparation, properties, and applications of thermoplastics & thermosetting & elastomers conducting polymers.

**CO3:** Explain the principles of spectrometry, slc in separation of solid and liquid mixtures.

**CO4:** Apply the principle of Band diagrams in the application of conductors and semiconductors.

**CO5:** Summarize the concepts of Instrumental methods.

**UNIT I: Structure and Bonding Models:**

Fundamentals of Quantum mechanics, Schrodinger Wave equation, significance of  $\Psi$  and  $\Psi^2$ , particle in one dimensional box, molecular orbital theory – bonding in homo- and heteronuclear diatomic molecules – energy level diagrams of O<sub>2</sub> and CO, etc.  $\pi$ -molecular orbitals of butadiene and benzene, calculation of bond order.

**UNIT II: Modern Engineering materials**

Semiconductors – Introduction, basic concept, application

Superconductors-Introduction basic concept, applications.

Supercapacitors: Introduction, Basic Concept-Classification – Applications.

Nano materials: Introduction, classification, properties and applications of Fullerenes, carbon nano tubes and Graphines nanoparticles.

**UNIT III: Electrochemistry and Applications**

Electrochemical cell, Nernst equation, cell potential calculations and numerical problems, potentiometry- potentiometric titrations (redox titrations), concept of conductivity, conductivity cell, conductometric titrations (acid-base titrations).

Electrochemical sensors – potentiometric sensors with examples, amperometric sensors with examples.

Primary cells – Zinc-air battery, Secondary cells –lithium-ion batteries- working of the batteries including cell reactions; Fuel cells, hydrogen-oxygenfuel cell– working of the cells.

Polymer Electrolyte Membrane Fuel cells (PEMFC).



#### **UNIT IV: Polymer Chemistry**

Introduction to polymers, functionality of monomers, chain growth and step growth polymerization, coordination polymerization, with specific examples and mechanisms of polymer formation.

Plastics –Thermo and Thermosetting plastics, Preparation, properties and applications of – PVC, Teflon, Bakelite, Nylon-6,6, carbon fibres.

Elastomers–Buna-S, Buna-N–preparation, properties and applications.

Conducting polymers – polyacetylene, polyaniline, – mechanism of conduction and applications. Bio-Degradable polymers - Poly Glycolic Acid (PGA), Polyl Lactic Acid (PLA).

#### **UNIT V: Instrumental Methods and Applications**

Electromagnetic spectrum. Absorption of radiation: Beer-Lambert's law. UV-Visible Spectroscopy, electronic transition, Instrumentation, IR spectroscopies, fundamental modes and selection rules, Instrumentation. Chromatography-Basic Principle, Classification-HPLC: Principle, Instrumentation and Applications.

#### **Textbooks:**

1. Jain and Jain, Engineering Chemistry, 16/e, DhanpatRai, 2013.
2. Peter Atkins, Julio de Paula and James Keeler, Atkins' Physical Chemistry, 10/e, Oxford University Press, 2010.

#### **Reference Books:**

1. Skoog and West, Principles of Instrumental Analysis, 6/e, Thomson, 2007.
2. J.D. Lee, Concise Inorganic Chemistry, 5<sup>th</sup> Edition, Wiley Publications, Feb.2008
3. Textbook of Polymer Science, Fred W. Billmayer Jr, 3rd Edition



**R23ES01**

L	T	P	C
3	0	0	3

**BASIC CIVIL AND MECHANICAL ENGINEERING**  
(Common to All Branches)

**Course Objectives:**

- Get familiarized with the scope and importance of Civil Engineering sub-divisions.
- Introduce the preliminary concepts of surveying.
- Acquire preliminary knowledge on Transportation and its importance in nation’s economy.
- Get familiarized with the importance of quality, conveyance and storage of water.
- Introduction to basic civil engineering materials and construction techniques.

**Course Outcomes:** On completion of the course, the student should be able to:

- CO1: Understand various sub-divisions of Civil Engineering and to appreciate their role in ensuring better society.
- CO2: Know the concepts of surveying and to understand the measurement of distances, angles and levels through surveying.
- CO3: Realize the importance of Transportation in nation's economy and the engineering measures related to Transportation.
- CO4: Understand the importance of Water Storage and Conveyance Structures so that the social responsibilities of water conservation will be appreciated.
- CO5: Understand the basic characteristics of Civil Engineering Materials and attain knowledge on prefabricated technology.

**UNIT I**

**Basics of Civil Engineering:** Role of Civil Engineers in Society- Various Disciplines of Civil Engineering- Structural Engineering- Geo-technical Engineering- Transportation Engineering - Hydraulics and Water Resources Engineering - Environmental Engineering-Scope of each discipline - Building Construction and Planning- Construction Materials-Cement - Aggregate - Bricks- Cement concrete- Steel. Introduction to Prefabricated Construction Techniques.

**UNIT II**

**Surveying:** Objectives of Surveying- Horizontal Measurements- Angular Measurements-Introduction to Bearings Levelling instruments used for levelling -Simple problems on levelling and Bearings- Contour mapping.

**UNIT III**

**Transportation Engineering** Importance of Transportation in Nation's economic development-Types of Highway Pavements- Flexible Pavements and Rigid Pavements - Simple Differences. Basics of Harbour, Tunnel, Airport, and Railway Engineering.

**Water Resources and Environmental Engineering:** Introduction, Sources of water- Quality of water- Specifications- Introduction to Hydrology–Rainwater Harvesting-Water Storage and Conveyance Structures (Simple introduction to Dams and Reservoirs).



**Textbooks:**

1. Basic Civil Engineering, M.S.Palanisamy, , Tata Mcgraw Hill publications (India) Pvt. Ltd. Fourth Edition.
2. Introduction to Civil Engineering, S.S. Bhavikatti, New Age International Publishers. 2022. First Edition.
3. Basic Civil Engineering, Satheesh Gopi, Pearson Publications, 2009, First Edition.

**Reference Books:**

1. Surveying, Vol- I and Vol-II, S.K. Duggal, Tata McGraw Hill Publishers 2019. Fifth Edition.
2. Hydrology and Water Resources Engineering, Santosh Kumar Garg, Khanna Publishers, Delhi. 2016
3. Irrigation Engineering and Hydraulic Structures - Santosh Kumar Garg, Khanna Publishers, Delhi 2023. 38<sup>th</sup> Edition.
4. Highway Engineering, S.K.Khanna, C.E.G. Justo and Veeraraghavan, Nemchand and Brothers Publications 2019. 10<sup>th</sup> Edition.

## PART B: BASIC MECHANICAL ENGINEERING

**Course Objectives:** The students after completing the course are expected to

- Get familiarized with the scope and importance of Mechanical Engineering in different sectors and industries.
- Explain different engineering materials and different manufacturing processes.
- Provide an overview of different thermal and mechanical transmission systems and introduce basics of robotics and its applications.

**Course Outcomes:** On completion of the course, the student should be able to

CO1: Understand the different manufacturing processes.

CO2: Explain the basics of thermal engineering and its applications.

CO3: Describe the working of different mechanical power transmission systems and power plants.

CO4: Describe the basics of robotics and its applications.

### UNIT I

**Introduction to Mechanical Engineering:** Role of Mechanical Engineering in Industries and Society- Technologies in different sectors such as Energy, Manufacturing, Automotive, Aerospace, and Marine sectors.

**Engineering Materials** - Metals-Ferrous and Non-ferrous, Ceramics, Composites, Smart materials.

### UNIT II

**Manufacturing Processes:** Principles of Casting, Forming, joining processes, Machining, Introduction to CNC machines, 3D printing, and Smart manufacturing.

**Thermal Engineering** – working principle of Boilers, Otto cycle, Diesel cycle, Refrigeration and air-conditioning cycles, IC engines, 2-Stroke and 4-Stroke engines, SI/CI Engines, Components of Electric and Hybrid Vehicles.

### UNIT III

**Power plants** – working principle of Steam, Diesel, Hydro, Nuclear power plants. **Mechanical**

**Power Transmission** - Belt Drives, Chain, Rope drives, Gear Drives and their applications.

**Introduction to Robotics** - Joints & links, configurations, and applications of robotics.



(Note: The subject covers only the basic principles of Civil and Mechanical Engineering systems. The evaluation shall be intended to test only the fundamentals of the subject)

**Textbooks:**

1. Internal Combustion Engines by V.Ganesan, By Tata McGraw Hill publications (India) Pvt. Ltd.
2. A Tear book of Theory of Machines by S.S. Rattan, Tata McGraw Hill Publications, (India) Pvt. Ltd.
3. An introduction to Mechanical Engg by Jonathan Wicker and Kemper Lewis, Cengage learning India Pvt. Ltd.

**Reference Books:**

1. Appuu Kuttan KK, Robotics, I.K. International Publishing House Pvt. Ltd. Volume-I
2. 3D printing & Additive Manufacturing Technology- L. Jyothish Kumar, Pulak M Pandey, Springer publications
3. Thermal Engineering by Mahesh M Rathore Tata McGraw Hill publications (India) Pvt. Ltd.
4. G. Shanmugam and M.S.Palanisamy, Basic Civil and the Mechanical Engineering, Tata McGraw Hill publications (India) Pvt. Ltd.



**R23ES07**

L	T	P	C
3	0	0	3

**INTRODUCTION TO PROGRAMMING**

(Common to All branches of Engineering)

**Course Objectives:**

- To introduce students to the fundamentals of computer programming.
- To provide hands-on experience with coding and debugging.
- To foster logical thinking and problem-solving skills using programming.
- To familiarize students with programming concepts such as data types, control structures, functions, and arrays.
- To encourage collaborative learning and teamwork in coding projects.

**Course Outcomes:** A student after completion of the course will be able to

- CO1: Understand basics of computers, the concept of algorithm and algorithmic thinking.
- CO2: Analyse a problem and develop an algorithm to solve it.
- CO3: Implement various algorithms using the C programming language.
- CO4: Understand more advanced features of C language.
- CO5: Develop problem-solving skills and the ability to debug and optimize the code.

**UNIT I: Introduction to Programming and Problem Solving**

History of Computers, Basic organization of a computer: ALU, input-output units, memory, program counter, Introduction to Programming Languages, Basics of a Computer Program-Algorithms, flowcharts (Using Dia Tool), pseudo code. Introduction to Compilation and Execution, Primitive Data Types, Variables, and Constants, Basic Input and Output, Operations, Type Conversion, and Casting.

Problem solving techniques: Algorithmic approach, characteristics of algorithm, Problem solving strategies: Top-down approach, Bottom-up approach, Time and space complexities of algorithms.

**UNIT II: Control Structures**

Simple sequential programs Conditional Statements (if, if-else, switch), Loops (for, while, do-while) Break and Continue.

**UNIT III: Arrays and Strings**

Arrays indexing, memory model, programs with array of integers, two dimensional arrays, Introduction to Strings.

**UNIT IV: Pointers & User Defined Data types**

Pointers, dereferencing and address operators, pointer and address arithmetic, array manipulation using pointers, User-defined data types -Structures and Unions.

**UNIT V: Functions & File Handling**

Introduction to Functions, Function Declaration and Definition, Function call Return Types and Arguments, modifying parameters inside functions using pointers, arrays as parameters. Scope and Lifetime of Variables, Basics of File Handling

**Note:** The syllabus is designed with C Language as the fundamental language of implementation.



**Textbooks:**

1. "The C Programming Language", Brian W. Kernighan and Dennis M. Ritchie, Prentice-Hall, 1988
2. Schaum's Outline of Programming with C, Byron S Gottfried, McGraw-Hill Education, 1996
3. Computing fundamentals and C Programming, Balagurusamy, E., McGraw-Hill Education, 2008.
4. Programming in C, Rema Theraja, Oxford, 2016, 2<sup>nd</sup> edition
5. C Programming, A Problem Solving Approach, Forouzan, Gilberg, Prasad, CENGAGE, 3<sup>rd</sup> edition



**R23HS01 – P**

L	T	P	C
0	0	2	1

**COMMUNICATIVE ENGLISH LAB  
(Common to All Branches of Engineering)**

**Course Objectives:**

The main objective of introducing this course, Communicative English Laboratory, is to expose the students to a variety of self-instructional, learner friendly modes of language learning. The students will get trained in basic communication skills and also make them ready to face job interviews.

**Course Outcomes:**

- CO1: Understand the different aspects of the English language proficiency with emphasis on LSRW skills.
- CO2: Apply communication skills through various language learning activities.
- CO3: Analyze the English speech sounds, stress, rhythm, intonation and syllable division for better listening and speaking comprehension.
- CO4: Evaluate and exhibit professionalism in participating in debates and group discussions.
- CO5: Create effective Course Objectives:

**List of Topics:**

1. Vowels & Consonants
2. Neutralization/Accent Rules
3. Communication Skills & JAM
4. Role Play or Conversational Practice
5. E-mail Writing
6. Resume Writing, Cover letter, SOP
7. Group Discussions-methods & practice
8. Debates - Methods & Practice
9. PPT Presentations/ Poster Presentation
10. Interviews Skills

**Suggested Software:**

1. Walden Infotech
2. Young India Films

**Reference Books:**

1. Raman Meenakshi, Sangeeta-Sharma. *Technical Communication*. Oxford Press.2018.
2. Taylor Grant: *English Conversation Practice*, Tata McGraw-Hill Education India, 2016
3. Hewing's, Martin. *Cambridge Academic English (B2)*. CUP, 2012.
4. J. Sethi & P.V. Dhamija. *A Course in Phonetics and Spoken English*, (2<sup>nd</sup> Ed) , Kindle, 2013



**R23BS01 – P**

L	T	P	C
0	0	2	1

**CHEMISTRY LAB**  
(Common to EEE, ECE & CSE)

**Course Objectives:**

Verify the fundamental concepts with experiments.

**Course Outcomes:** At the end of the course, the students will be able to

- CO1:** Determine the cell constant and conductance of solutions.
- CO2:** Prepare advanced polymer Bakelite materials.
- CO3:** Measure the strength of an acid present in secondary batteries.
- CO4:** Calculate the strength of acids by using permanganometry
- CO5:** Calculate strength of acid in Pb-Acid battery.

**List of Experiments:**

1. Measurement of 10Dq by spectrophotometric method
2. Conductometric titration of strong acid vs. strong base
3. Conductometric titration of weak acid vs. strong base
4. Determination of cell constant and conductance of solutions
5. Potentiometry - determination of redox potentials and emfs
6. Determination of Strength of an acid in Pb-Acid battery
7. Preparation of a Bakelite
8. Verify Lambert-Beer's law
9. Wavelength measurement of sample through UV-Visible Spectroscopy
10. Identification of simple organic compounds by IR
11. Preparation of nanomaterials by precipitation method
12. Estimation of Ferrous Iron by Dichrometry
13. Determination of Fe(II) Mohr's salts by Permanganometry
14. Determination of Oxalic Acid by Permanganometry
15. Determination of Chromium(VI) by Mohr's salt solution

**Reference:**

"Vogel's Quantitative Chemical Analysis 6th Edition 6th Edition" Pearson Publications by J. Mendham, R.C.Denney, J.D.Barnes and B. Sivasankar



**R23ES02 – P**

L	T	P	C
0	0	3	1.5

**ENGINEERING WORKSHOP**

(Common to All branches of Engineering)

**Course Objectives:**

To familiarize students with wood working, sheet metal operations, fitting and electrical house wiring skills

**Course Outcomes:**

CO1: Identify workshop tools and their operational capabilities.

CO2: Practice on manufacturing of components using workshop trades including fitting, carpentry, foundry and welding.

CO3: Apply fitting operations in various applications.

CO4: Apply basic electrical engineering knowledge for House Wiring Practice

**SYLLABUS**

1. **Demonstration:** Safety practices and precautions to be observed in workshop.
2. **Wood Working:** Familiarity with different types of woods and tools used in wood working and make following joints.
  - a) Half – Lap joint      b) Mortise and Tenon joint    c) Corner Dovetail joint or Bridle joint
3. **Sheet Metal Working:** Familiarity with different types of tools used in sheet metal working, Developments of following sheet metal job from GI sheets.
  - a) Tapered tray            b) Conical funnel            c) Elbow pipe            d) Brazing
4. **Fitting:** Familiarity with different types of tools used in fitting and do the following fitting exercises.
  - a) V-fit                    b) Dovetail fit            c) Semi-circular fit      d) Bicycle tire puncture

and change of two-wheeler tyre
5. **Electrical Wiring:** Familiarity with different types of basic electrical circuits and make the following connections.
  - a) Parallel and series b) Two-way switch c) Godown lighting d) Tube light e) Three phase motor f) Soldering of wires



6. **Foundry Trade:** Demonstration and practice on Moulding tools and processes, Preparation of Green Sand Moulds for given Patterns.
7. **Welding Shop:** Demonstration and practice on Arc Welding and Gas welding. Preparation of Lap joint and Butt joint.
8. **Plumbing:** Demonstration and practice of Plumbing tools, Preparation of Pipe joints with coupling for same diameter and with reducer for different diameters.

**Textbooks:**

1. Basic Workshop Technology: Manufacturing Process, Felix W.; Independently Published, 2019. Workshop Processes, Practices and Materials; Bruce J. Black, Routledge publishers, 5th Edn. 2015.
2. A Course in Workshop Technology Vol I. & II, B.S. Raghuwanshi, Dhanpath Rai & Co., 2015 & 2017.

**Reference Books:**

1. Elements of Workshop Technology, Vol. I by S. K. Hajra Choudhury & Others, Media Promoters and Publishers, Mumbai. 2007, 14th edition
2. Workshop Practice by H. S. Bawa, Tata-McGraw Hill, 2004.
3. Wiring Estimating, Costing and Contracting; Soni P.M. & Upadhyay P.A.; Atul Prakashan, 2021-22.



**R23ES07-P**

L	T	P	C
0	0	3	1.5

**COMPUTER PROGRAMMING LAB**  
(Common to All branches of Engineering)

**Course Objectives:**

The course aims to give students hands – on experience and train them on the concepts of the C-programming language.

**Course Outcomes:**

CO1: Read, understand, and trace the execution of programs written in C language.

CO2: Select the right control structure for solving the problem.

CO3: Develop C programs which utilize memory efficiently using programming constructs like pointers.

CO4: Develop, Debug and Execute programs to demonstrate the applications of arrays, functions, basic concepts of pointers in C.

**UNIT I**

**WEEK 1**

**Objective:** Getting familiar with the programming environment on the computer and writing the first program.

**Suggested Experiments/Activities:**

**Tutorial 1:** Problem-solving using Computers.

**Lab1:** Familiarization with programming environment

- i) Basic Linux environment and its editors like Vi, Vim & Emacs etc.
- ii) Exposure to Turbo C, gcc
- iii) Writing simple programs using printf(), scanf()

**WEEK 2**

**Objective:** Getting familiar with how to formally describe a solution to a problem in a series of finite steps both using textual notation and graphic notation.

**Suggested Experiments /Activities:**

**Tutorial 2:** Problem-solving using Algorithms and Flow charts.

**Lab 1:** Converting algorithms/flow charts into C Source code.

Developing the algorithms/flowcharts for the following sample programs

- i) Sum and average of 3 numbers
- ii) Conversion of Fahrenheit to Celsius and vice versa
- iii) Simple interest calculation

**WEEK 3**

**Objective:** Learn how to define variables with the desired data-type, initialize them with appropriate values and how arithmetic operators can be used with variables and constants.

**Suggested Experiments/Activities:**

**Tutorial 3:** Variable types and type conversions:

**Lab 3:** Simple computational problems using arithmetic expressions.



- i) Finding the square root of a given number
- ii) Finding compound interest
- iii) Area of a triangle using heron's formulae
- iv) Distance travelled by an object

## UNIT II

### WEEK 4

**Objective:** Explore the full scope of expressions, type-compatibility of variables & constants and operators used in the expression and how operator precedence works.

#### Suggested Experiments/Activities:

**Tutorial4:** Operators and the precedence and as associativity:

**Lab4:** Simple computational problems using the operator' precedence and associativity

- i) Evaluate the following expressions.
  - a.  $A+B*C+(D*E) + F*G$
  - b.  $A/B*C-B+A*D/3$
  - c.  $A+++B---A$
  - d.  $J= (i++) + (++i)$
- ii) Find the maximum of three numbers using conditional operator
- iii) Take marks of 5 subjects in integers, and find the total, average in float

### WEEK 5

**Objective:** Explore the full scope of different variants of “if construct” namely if-else, else – if , switch and nested-if including in what scenario each one of them can be used and how to use them. Explore all relational and logical operators while writing conditionals for “if construct”.

#### Suggested Experiments/Activities:

**Tutorial 5:** Branching and logical expressions:

**Lab 5:** Problems involving if-then-else structures.

- i) Write a C program to find the max and min of four numbers using if-else.
- ii) Write a C program to generate electricity bill.
- iii) Find the roots of the quadratic equation.
- iv) Write a C program to simulate a calculator using switch case.
- v) Write a C program to find the given year is a leap year or not.

### WEEK 6

**Objective:** Explore the full scope of iterative constructs namely while loop, do-while loop and for loop in addition to structured jump constructs like break and continue including when each of these statements is more appropriate to use.

#### Suggested Experiments/Activities:

**Tutorial 6:** Loops, while and for loops

**Lab 6:** Iterative problems e.g., the sum of series

- i) Find the factorial of given number using any loop.
- ii) Find the given number is a prime or not.
- iii) Compute sine and cos series
- iv) Checking a number palindrome
- v) Construct a pyramid of numbers.



## UNIT III

### WEEK 7:

**Objective:** Explore the full scope of Arrays construct namely defining and initializing 1-D and 2-D and more generically n-D arrays and referencing individual array elements from the defined array. Using integer 1-D arrays, explore search solution linear search.

#### Suggested Experiments/Activities:

**Tutorial 7:** 1-D Arrays: searching.

**Lab 7:** 1-D Array manipulation, linear search

- i) Find the min and max of a 1-D integer array.
- ii) Perform linear search on 1-D array.
- iii) The reverse of a 1-D integer array
- iv) Find 2's complement of the given binary number.
- v) Eliminate duplicate elements in an array.

### WEEK 8:

**Objective:** Explore the difference between other arrays and character arrays that can be used as Strings by using null character and get comfortable with string by doing experiments that will reverse a string and concatenate two strings. Explore sorting solution bubble sort using integer arrays.

#### Suggested Experiments/Activities:

**Tutorial 8:** 2 D arrays, sorting and Strings.

**Lab 8:** Matrix problems, String operations, Bubble sort

- i) Addition of two matrices
- ii) Multiplication two matrices
- iii) Sort array elements using bubble sort
- iv) Concatenate two strings without built-in functions
- v) Reverse a string using built-in and without built-in string functions

## UNIT IV

### WEEK 9:

**Objective:** Explore pointers to manage a dynamic array of integers, including memory allocation ; value initialization, resizing changing and reordering the contents of an array and memory de-allocation using malloc (), calloc (), realloc () and free () functions. Gain experience processing command-line arguments received by C

#### Suggested Experiments/Activities:

**Tutorial 9:** Pointers, structures and dynamic memory allocation

**Lab 9:** Pointers and structures, memory dereference.

- i) Write a C program to find the sum of a 1-D array using malloc()
- ii) Write a C program to find the total, average of n students using structures
- iii) Enter n students data using calloc() and display failed students list
- iv) Read student name and marks from the command line and display the student details along with the total.
- v) Write a C program to implement realloc()

### WEEK 10:

**Objective:** Experiment with C Structures, Unions, bit fields and self-referential structures (Singly linked lists) and nested structures



**Suggested Experiments/Activities:**

**Tutorial 10:** Bitfields, Self-Referential Structures, Linked lists

**Lab10 :** Bitfields, linked lists

Read and print a date using dd/mm/yyyy format using bit-fields and differentiate the same without using bit- fields

- i) Create and display a singly linked list using self-referential structure.
- ii) Demonstrate the differences between structures and unions using a C program.
- iii) Write a C program to shift/rotate using bitfields.
- iv) Write a C program to copy one structure variable to another structure of the same type.

**UNIT V**

**WEEK 11:**

**Objective:** Explore the Functions, sub-routines, scope and extent of variables, doing some experiments by parameter passing using call by value. Basic methods of numerical integration

**Suggested Experiments/Activities:**

**Tutorial 11:** Functions, call by value, scope and extent,

**Lab 11:** Simple functions using call by value, solving differential equations using Eulers theorem.

- i) Write a C function to calculate NCR value ( $nCr = n! / r! * (n-r!)$ ).
- ii) Write a C function to find the length of a string.
- iii) Write a C function to transpose of a matrix.
- iv) Write a C function to demonstrate numerical integration of differential equations using Euler's method

**WEEK 12:**

**Objective:** Explore how recursive solutions can be programmed by writing recursive functions that can be invoked from the main by programming at-least five distinct problems that have naturally recursive solutions.

**Suggested Experiments/Activities:**

**Tutorial 12:** Recursion, the structure of recursive calls

**Lab 12:** Recursive functions

- i) Write a recursive function to generate Fibonacci series.
- ii) Write a recursive function to find the LCM (Least Common Multiple) of two numbers.
- iii) Write a recursive function to find the factorial of a number.
- iv) Write a C Program to implement Ackermann function using recursion.
- v) Write a recursive function to find the sum of series.

**WEEK 13:**

**Objective:** Explore the basic difference between normal and pointer variables, Arithmetic operations using pointers and passing variables to functions using pointers

**Suggested Experiments/Activities:**

**Tutorial 13:** Call by reference, dangling pointers

**Lab 13:** Simple functions using Call by reference, Dangling pointers.

- i) Write a C program to swap two numbers using call by reference.
- ii) Demonstrate Dangling pointer problem using a C program.
- iii) Write a C program to copy one string into another using pointer.
- iv) Write a C program to find number of lowercase, uppercase, digits and other characters using pointers.



**WEEK14:**

**Objective:** To understand data files and file handling with various file I/O functions. Explore the differences between text and binary files.

**Suggested Experiments/Activities:**

**Tutorial 14:** File handling

**Lab 14:** File operations

- i) Write a C program to write and read text into a file.
- ii) Write a C program to write and read text into a binary file using fread() and fwrite()
- iii) Copy the contents of one file to another file.
- iv) Write a C program to merge two files into the third file using command-line arguments.
- v) Find number of lines, words and characters in a file
- vi) Write a C program to print last n characters of a given file.

**Textbooks:**

- 1) Ajay Mittal, Programming in C: A practical approach, Pearson.
- 2) Byron Gottfried, Schaum's Outline of Programming with C, McGraw Hill

**Reference Books:**

- 1) Brian W. Kernighan and Dennis M. Ritchie, The C Programming Language, Prentice-Hall of India
- 2) C Programming, A Problem-Solving Approach, Forouzan, Gilberg, Prasad, CENGAGE



**R23MC01**

L	T	P	C
0	0	1	0.5

**HEALTH AND WELLNESS, YOGA AND SPORTS**  
(Common to All branches of Engineering)

**Course Objectives:**

The main objective of introducing this course is to make the students maintain their mental and physical wellness by balancing emotions in their life. It mainly enhances the essential traits required for the development of the personality.

**Course Outcomes:** After completion of the course the student will be able to

- CO1:** Understand the importance of yoga and sports for Physical fitness and sound health.
- CO2:** Demonstrate an understanding of health-related fitness components.
- CO3:** Compare and contrast various activities that help enhance their health.
- CO4:** Assess current personal fitness levels.
- CO5:** Develop Positive Personality

**UNIT I**

Concept of health and fitness, Nutrition and Balanced diet, basic concept of immunity Relationship between diet and fitness, Globalization and its impact on health, Body Mass Index (BMI) of all age groups.

**Activities:**

- i) Organizing health awareness programmes in community
- ii) Preparation of health profile
- iii) Preparation of chart for balance diet for all age groups

**UNIT II**

Concept of yoga, need for and importance of yoga, origin and history of yoga in Indian context, classification of yoga, Physiological effects of Asanas- Pranayama and meditation, stress management and yoga, Mental health and yoga practice.

**Activities:**

Yoga practices – Asana, Kriya, Mudra, Bandha, Dhyana, Surya Namaskar

**UNIT III**

Concept of Sports and fitness, importance, fitness components, history of sports, Ancient and Modern Olympics, Asian games and Commonwealth games.

**Activities:**



1. Participation in one major game and one individual sport viz., Athletics, Volleyball, Basketball, Handball, Football, Badminton, Kabaddi, Kho-kho, Table tennis, Cricket etc.
2. Practicing general and specific warm up, aerobics
3. Practicing cardiorespiratory fitness, treadmill, run test, 9 min walk, skipping and running.

**Reference Books:**

1. Gordon Edlin, Eric Golanty. Health and Wellness, 14th Edn. Jones & Bartlett Learning, 2022
2. T.K.V.Desikachar. The Heart of Yoga: Developing a Personal Practice
3. Archie J.Bahm. Yoga Sutras of Patanjali, Jain Publishing Company, 1993
4. Wiseman, John Lofty, SAS Survival Handbook: The Ultimate Guide to Surviving Anywhere Third Edition, William Morrow Paperbacks, 2014
5. The Sports Rules Book/ Human Kinetics with Thomas Hanlon. -- 3rd ed. Human Kinetics, Inc.2014

**General Guidelines:**

1. Institutes must assign slots in the Timetable for the activities of Health/Sports/Yoga.
2. Institutes must provide field/facility and offer the minimum of five choices of as many as Games/Sports.
3. Institutes are required to provide sports instructor / yoga teacher to mentor the students.

**Evaluation Guidelines:**

- Evaluated for a total of 100 marks.
- A student can select 6 activities of his/her choice with a minimum of 01 activity per unit. Each activity shall be evaluated by the concerned teacher for 15 marks, totalling to 90 marks.
- A student shall be evaluated by the concerned teacher for 10 marks by conducting viva voce on the subject.



**B.Tech. – I Year II Semester (EIE)**

S.No.	Category	Title	L/D	T	P	Credits
1	R23BS03	Engineering Physics	3	0	0	3
2	R23BS02	Differential Equations & Vector Calculus	3	0	0	3
3	R23ES03	Engineering Graphics	3	0	0	3
4	R23ES04	Basic Electrical and Electronics Engineering	1	0	4	3
5	R23PC04	Network Analysis	3	0	0	3
6	R23ES06-P	IT Workshop	0	0	2	1
7	R23BS03-P	Engineering Physics Lab	0	0	2	1
8	R23ES04-P	Electrical and Electronics Engineering Workshop	0	0	3	1.5
9	R23PC04-P	Network Analysis and Simulation Lab	0	0	3	1.5
10	R23MC02	NSS/NCC/Scouts & Guides/Community Service	-	-	1	0.5
<b>Total</b>			<b>13</b>	<b>00</b>	<b>15</b>	<b>20.5</b>



**R23BS02**

L	T	P	C
3	0	0	3

**DIFFERENTIAL EQUATIONS AND VECTOR CALCULUS**  
(Common to All Branches of Engineering)

**Course Objectives:**

- To enlighten the learners in the concept of differential equations and multivariable calculus.
- To furnish the learners with basic concepts and techniques at plus two level to lead them into advanced level by handling various real-world applications.

**Course Outcomes:** At the end of the course, the student will be able to

CO1: Solve the differential equations related to various engineering fields.

CO2: Identify solution methods for partial differential equations that model physical processes.

CO3: Interpret the physical meaning of different operators such as gradient, curl and divergence.

CO4: Estimate the work done against a field, circulation and flux using vector calculus.

**UNIT I Differential equations of first order and first degree**

Linear differential equations – Bernoulli’s equations- Exact equations and equations reducible to exact form. Applications: Newton’s Law of cooling – Law of natural growth and decay -Electrical circuits.

**UNIT II Linear differential equations of higher order with Constant Coefficients**

Definitions, homogenous and non-homogenous, complimentary function, general solution, particular integral, Method of variation of parameters, Simultaneous linear equations, Applications to L-C-R Circuit problems.

**UNIT III Partial Differential Equations**

Introduction and formation of Partial Differential Equations by elimination of arbitrary constants and arbitrary functions, solutions of first order linear equations using Lagrange’s method. Homogeneous Linear Partial differential equations with constant coefficients.

**UNIT IV Vector differentiation**

Scalar and vector point functions, vector operator Del, Del applies to scalar point functions -Gradient, Directional derivative, del applied to vector point functions -Divergence and Curl, vector identities.

**UNIT V Vector integration**

Line integral-circulation-work done, surface integral-flux, Green’s theorem in the plane (without proof), Stoke’s theorem (without proof), volume integral, Gauss Divergence theorem (without proof) and related problems.

**Textbooks:**

1. Higher Engineering Mathematics, B. S. Grewal, Khanna Publishers, 2017, 44th Edition
2. Higher Engineering Mathematics, B. V. Ramana, McGraw Hill Education, 2017.
3. Engineering Matematics-I, Dr.Sk.Vali, Dr. G.Venkata Rao and Dr.A.V Paparao,Cengage Publication 2017.



**R23BS03**

L	T	P	C
3	0	0	3

**ENGINEERING PHYSICS**  
(Common for all branches of Engineering)

**Course Objectives:**

To bridge the gap between the Physics in school at 10+2 level and UG level engineering courses by identifying the importance of the optical phenomenon like interference, diffraction etc, enlightening the periodic arrangement of atoms in crystalline solids and concepts of quantum mechanics, introduce novel concepts of dielectric and magnetic materials, physics of semiconductors.

**Course Outcomes:**

- CO1: Analyze the intensity variation of light due to polarization, interference and diffraction.
- CO2: Familiarize with the basics of crystals and their structures.
- CO3: Explain fundamentals of quantum mechanics and apply it to one dimensional motion of particles.
- CO4: Summarize various types of polarization of dielectrics and classify the magnetic materials.
- CO5: Explain the basic concepts of Quantum Mechanics and the band theory of solids.
- CO6: Identify the type of semiconductor using Hall effect.

**UNIT I: Wave Optics**

Interference: Introduction - Principle of superposition –Interference of light - Interference in thin films (Reflection Geometry) & applications - Colours in thin films- Newton’s Rings, Determination of wavelength and refractive index.

Diffraction: Introduction - Fresnel and Fraunhofer diffractions - Fraunhofer diffraction due to single slit, double slit & N-slits (Qualitative) – Diffraction Grating - Dispersive power and resolving power of Grating (Qualitative). Polarization: Introduction -Types of polarization - Polarization by reflection, refraction and Double refraction - Nicol’s Prism -Half wave and Quarter wave plates.

**UNIT II: Crystallography and X-ray diffraction**

Crystallography: Space lattice, Basis, Unit Cell and lattice parameters – Bravais Lattices – crystal systems (3D) – coordination number - packing fraction of SC, BCC & FCC - Miller indices – separation between successive (hkl) planes.

X-ray diffraction: Bragg’s law - X-ray Diffractometer – crystal structure determination by Laue’s and powder methods

**UNIT III: Dielectric and Magnetic Materials**

Dielectric Materials: Introduction - Dielectric polarization - Dielectric polarizability, Susceptibility, Dielectric constant and Displacement Vector – Relation between the electric vectors - Types of polarizations- Electronic (Quantitative), Ionic (Quantitative) and Orientation polarizations (Qualitative) - Lorentz internal field - Clausius- Mossotti equation - complex dielectric constant – Frequency dependence of polarization – dielectric loss

Magnetic Materials: Introduction - Magnetic dipole moment - Magnetization-Magnetic susceptibility and permeability – Atomic origin of magnetism - Classification of magnetic materials: Dia, para,



Ferro, anti-ferro & Ferri magnetic materials - Domain concept for Ferromagnetism & Domain walls (Qualitative) - Hysteresis - soft and hard magnetic materials.

#### **UNIT IV: Quantum Mechanics and Free Electron Theory**

Quantum Mechanics: Dual nature of matter – Heisenberg’s Uncertainty Principle – Significance and properties of wave function – Schrodinger’s time independent and dependent wave equations– Particle in a one-dimensional infinite potential well.

Free Electron Theory: Classical free electron theory (Qualitative with discussion of merits and demerits) – Quantum free electron theory – electrical conductivity based on quantum free electron theory - Fermi-Dirac distribution - Density of states - Fermi energy

#### **UNIT V Semiconductors**

Semiconductors: Formation of energy bands – classification of crystalline solids - Intrinsic semiconductors: Density of charge carriers – Electrical conductivity – Fermi level – Extrinsic semiconductors: density of charge carriers – dependence of Fermi energy on carrier concentration and temperature - Drift and diffusion currents – Einstein’s equation – Hall effect and its applications.

#### **Textbooks:**

1. A Text book of Engineering Physics, M. N. Avadhanulu, P.G.Kshirsagar & TVS Arun Murthy, S. Chand Publications, 11th Edition 2019.
2. Engineering Physics - D.K.Bhattacharya and Poonam Tandon, Oxford press (2015)

#### **Reference Books:**

1. Engineering Physics - B.K. Pandey and S. Chaturvedi, Cengage Learning 2021.
2. Engineering Physics - Shatendra Sharma, Jyotsna Sharma, Pearson Education, 2018.
3. Engineering Physics” - Sanjay D. Jain, D. Sahasrabudhe and Girish, University Press. 2010
4. Engineering Physics - M.R. Srinivasan, New Age international publishers (2009).

**Web Resources:** <https://www.loc.gov/rr/scitech/selected-internet/physics.html>



R23ES03

L	T	P	C
1	0	4	3

**ENGINEERING GRAPHICS**  
(Common to All branches of Engineering)

**Course Objectives:**

- To enable the students with various concepts like dimensioning, conventions and standards related to Engineering Drawing
- To impart knowledge on the projection of points, lines and plane surfaces
- To improve the visualization skills for better understanding of projection of solids
- To develop the imaginative skills of the students required to understand Section of solids and Developments of surfaces.
- To make the students understand the viewing perception of a solid object in Isometric and Perspective projections.

**Course Outcomes:**

CO1: Understand the principles of engineering drawing, including engineering curves, scales, orthographic and isometric projections.

CO2: Draw and interpret orthographic projections of points, lines, planes and solids in front, top and side views.

CO3: Understand and draw projection of solids in various positions in first quadrant.

CO4: Explain principles behind development of surfaces.

CO5: Prepare isometric and perspective sections of simple solids.

**UNIT I**

**Introduction:** Lines, Lettering and Dimensioning, Geometrical Constructions and Constructing regular polygons by general methods.

**Curves:** construction of ellipse, parabola and hyperbola by general, Cycloids, Involutives, Normal and tangent to Curves.

**Scales:** Plain scales, diagonal scales and vernier scales.

**UNIT II**

**Orthographic Projections:** Reference plane, importance of reference lines or Plane, Projections of a point situated in any one of the four quadrants.

**Projections of Straight Lines:** Projections of straight lines parallel to both reference planes, perpendicular to one reference plane and parallel to other reference plane, inclined to one reference plane and parallel to the other reference plane. Projections of Straight Line Inclined to both the reference planes

**Projections of Planes:** regular planes Perpendicular to both reference planes, parallel to one reference plane and inclined to the other reference plane; plane inclined to both the reference planes.



### UNIT III

**Projections of Solids:** Types of solids: Polyhedra and Solids of revolution. Projections of solids in simple positions: Axis perpendicular to horizontal plane, Axis perpendicular to vertical plane and Axis parallel to both the reference planes, Projection of Solids with axis inclined to one reference plane and parallel to another plane.

### UNIT IV

**Sections of Solids:** Perpendicular and inclined section planes, Sectional views and True shape of section, Sections of solids in simple position only.

**Development of Surfaces:** Methods of Development: Parallel line development and radial line development. Development of a cube, prism, cylinder, pyramid and cone.

### UNIT V

**Conversion of Views:** Conversion of isometric views to orthographic views; Conversion of orthographic views to isometric views.

**Computer graphics:** Creating 2D&3D drawings of objects including PCB and Transformations using Auto CAD (*Not for end examination*).

#### Textbook:

1. N. D. Bhatt, Engineering Drawing, Charotar Publishing House, 2016.

#### Reference Books:

1. Engineering Drawing, K.L. Narayana and P. Kanniah, Tata McGraw Hill, 2013.
2. Engineering Drawing, M.B.Shah and B.C. Rana, Pearson Education Inc, 2009.
3. Engineering Drawing with an Introduction to AutoCAD, Dhananjay Jolhe, Tata McGraw Hill, 2017.



**R23ES04**

L	T	P	C
3	0	0	3

## **BASIC ELECTRICAL & ELECTRONICS ENGINEERING**

(Common to All branches of Engineering)

### **Course Objectives**

To expose to the field of electrical & electronics engineering, laws and principles of electrical/electronic engineering and to acquire fundamental knowledge in the relevant field.

**Course Outcomes:** After the completion of the course students will be able to

### **Course Outcomes:**

- CO1:** Remember the fundamental laws, operating principles of motors, generators, MC and MI instruments.
- CO2:** Understand the problem solving concepts associated to AC and DC circuits, construction and operation of AC and DC machines, measuring instruments; different power generation mechanisms, Electricity billing concept and important safety measures related to electrical operations.
- CO3:** Apply mathematical tools and fundamental concepts to derive various equations related to machines, circuits and measuring instruments; electricity bill calculations and layout representation of electrical power systems.
- CO4:** Analyze different electrical circuits, performance of machines and measuring instruments.
- CO5:** Evaluate different circuit configurations, Machine performance and Power systems operation.

### **PART A: BASIC ELECTRICAL ENGINEERING**

#### **UNIT I DC & AC Circuits**

**DC Circuits:** Electrical circuit elements (R, L and C), Ohm's Law and its limitations, KCL & KVL, series, parallel, series-parallel circuits, Super Position theorem, Simple numerical problems.

**AC Circuits:** A.C. Fundamentals: Equation of AC Voltage and current, waveform, time period, frequency, amplitude, phase, phase difference, average value, RMS value, form factor, peak factor, Voltage and current relationship with phasor diagrams in R, L, and C circuits, Concept of Impedance, Active power, reactive power and apparent power, Concept of power factor (Simple Numerical problems).

#### **UNIT II Machines and Measuring Instruments**

**Machines:** Construction, principle and operation of (i) DC Motor, (ii) DC Generator, (iii) Single Phase Transformer, (iv) Three Phase Induction Motor and (v) Alternator, Applications of electrical machines.

**Measuring Instruments:** Construction and working principle of Permanent Magnet Moving Coil (PMMC), Moving Iron (MI) Instruments and Wheat Stone bridge.

#### **UNIT III Energy Resources, Electricity Bill & Safety Measures**



**Energy Resources:** Conventional and non-conventional energy resources; Layout and operation of various Power Generation systems: Hydel, Nuclear, Solar & Wind power generation.

**Electricity bill:** Power rating of household appliances including air conditioners, PCs, Laptops, Printers, etc. Definition of “unit” used for consumption of electrical energy, two-part electricity tariff, calculation of electricity bill for domestic consumers.

**Equipment Safety Measures:** Working principle of Fuse and Miniature circuit breaker (MCB), merits and demerits. Personal safety measures: Electric Shock, Earthing and its types, Safety Precautions to avoid shock.

**Textbooks:**

1. Basic Electrical Engineering, D. C. Kulshreshtha, Tata McGraw Hill, 2019, First Edition
2. Power System Engineering, P.V. Gupta, M.L. Soni, U.S. Bhatnagar and A. Chakrabarti, Dhanpat Rai & Co, 2013
3. Fundamentals of Electrical Engineering, Rajendra Prasad, PHI publishers, 2014, Third Edition

**Reference Books:**

1. Basic Electrical Engineering, D. P. Kothari and I. J. Nagrath, Mc Graw Hill, 2019, Fourth Edition
2. Principles of Power Systems, V.K. Mehtha, S.Chand Technical Publishers, 2020
3. Basic Electrical Engineering, T. K. Nagsarkar and M. S. Sukhija, Oxford University Press, 2017
4. Basic Electrical and Electronics Engineering, S. K. Bhattacharya, Person Publications, 2018, Second Edition.

**Web Resources:**

1. <https://nptel.ac.in/courses/108105053>
2. <https://nptel.ac.in/courses/108108076>

## PART B: BASIC ELECTRONICS ENGINEERING

**Course Objectives:**

- To teach the fundamentals of semiconductor devices and its applications, principles of digital electronics.

### UNIT I SEMICONDUCTOR DEVICES

Introduction - Evolution of electronics – Vacuum tubes to nano electronics - Characteristics of PN Junction Diode — Zener Effect — Zener Diode and its Characteristics. Bipolar Junction Transistor — CB, CE, CC Configurations and Characteristics — Elementary Treatment of Small Signal CE Amplifier.

### UNIT II BASIC ELECTRONIC CIRCUITS AND INSTRUMENTATION

Rectifiers and power supplies: Block diagram description of a dc power supply, working of a full wave bridge rectifier, capacitor filter (no analysis), working of simple zener voltage regulator.



Amplifiers: Block diagram of Public Address system, Circuit diagram and working of common emitter (RC coupled) amplifier with its frequency response. Electronic Instrumentation: Block diagram of an electronic instrumentation system.

### **UNIT III      DIGITAL ELECTRONICS**

Overview of Number Systems, Logic gates including Universal Gates, BCD codes, Excess-3 code, Gray code, Hamming code. Boolean Algebra, Basic Theorems and properties of Boolean Algebra, Truth Tables and Functionality of Logic Gates – NOT, OR, AND, NOR, NAND, XOR and XNOR. Simple combinational circuits–Half and Full Adders. Introduction to sequential circuits, Flip flops, Registers and counters (Elementary Treatment only)

#### **Textbooks:**

1. R. L. Boylestad & Louis Nashlesky, Electronic Devices & Circuit Theory, Pearson Education, 2021.
2. R. P. Jain, Modern Digital Electronics, 4<sup>th</sup> Edition, Tata Mc Graw Hill, 2009

#### **Reference Books:**

1. R. S. Sedha, A Textbook of Electronic Devices and Circuits, S. Chand & Co, 2010.
2. Santiram Kal, Basic Electronics- Devices, Circuits and IT Fundamentals, Prentice Hall, India, 2002.
3. R. T. Paynter, Introductory Electronic Devices & Circuits – Conventional Flow Version, Pearson Education, 2009.



**R23PC04**

L	T	P	C
3	0	0	3

**NETWORK ANALYSIS**  
(ECE & EIE branches)

**Course Objectives:**

- To introduce basic laws, mesh & nodal analysis techniques for solving electrical circuits
- To impart knowledge on applying appropriate theorem for electrical circuit analysis
- To explain transient behavior of circuits in time and frequency domains
- To teach concepts of resonance
- To introduce open circuit, short circuit, transmission, hybrid parameters and their interrelationship.

**Course Outcomes:** At the end of this course students will demonstrate the ability to

- CO1: Understand basic electrical circuits with nodal and mesh analysis.
- CO2: Analyse the circuit using network simplification theorems.
- CO3: Find Transient response and Steady state response of a network.
- CO4: Analyse electrical networks in the Laplace domain.
- CO5: Compute the parameters of a two-port network.

**UNIT I**

Types of circuit components, Types of Sources and Source Transformations, Mesh analysis and Nodal analysis, problem solving with resistances only including dependent sources also. Principle of Duality with examples.

Network Theorems: Thevenin's, Norton's, Milliman's, Reciprocity, Compensation, Substitution, Superposition, Max Power Transfer, Tellegens - problem solving using dependent sources also.

**UNIT II**

Transients: First order differential equations, Definition of time constants, R-L circuit, R-C circuit with DC excitation, evaluating initial conditions procedure, second order differential equations, homogeneous, non-homogenous, problem-solving using R-L-C elements with DC excitation and AC excitation, Response as related to s-plane rotation of roots.

Laplace transform: introduction, Laplace transformation, basic theorems, problem solving using Laplace transform, partial fraction expansion, Heaviside's expansions, problem solving using Laplace transform.

**UNIT III**

Steady State Analysis of A.C Circuits: Impedance concept, phase angle, series R-L, R-C, R-L-C circuits problem solving. Complex impedance and phasor notation for R-L, R-C, R-L-C problem solving using mesh and nodal analysis, Star-Delta conversion, problem solving using Laplace transforms also.



## UNIT IV

Resonance: Introduction, Definition of Q, Series resonance, Bandwidth of series resonance, Parallel resonance, general case-resistance present in both branches, anti-resonance at all frequencies.

Coupled Circuits: Coupled Circuits: Self-inductance, Mutual inductance, Coefficient of coupling, analysis of coupled circuits, Natural current, Dot rule of coupled circuits, conductively coupled equivalent circuits- problem solving.

## UNIT V

Two-port Networks: Relationship of two port networks, Z-parameters, Y-parameters, Transmission line parameters, h- parameters, Relationships Between parameter Sets, Parallel & series connection of two port networks, cascading of two port networks, problem solving using dependent sources also.

Image and iterative impedances. Image and iterative transfer constants. Insertion loss. Attenuators and pads. Lattice network and its parameters. Impedance matching networks.

### Textbooks:

1. Network Analysis – ME Van Valkenburg, Prentice Hall of India, revised 3rd Edition, 2019.
2. Engineering Circuit Analysis by William H. Hayt, Jack Kemmerly, Jamie Phillips, Steven M. Durbin, 9<sup>th</sup> Edition 2020.
3. Network lines and Fields by John. D. Ryder 2<sup>nd</sup> Edition, PHI

### Reference Books:

1. D. Roy Choudhury, Networks and Systems, New Age International Publications, 2013.
2. Joseph Edminister and Mahmood Nahvi, Electric Circuits, Schaum's Outline Series, 7<sup>th</sup> Edition, Tata McGraw Hill Publishing Company, New Delhi, 2017
3. Fundamentals of Electric Circuits by Charles K. Alexander and Matthew N. O. Sadiku, McGraw-Hill Education.



**R23ES06-P**

L	T	P	C
0	0	2	1

**IT WORKSHOP**

(Common to all branches of Engineering)

**Course Objectives:**

- To introduce the internal parts of a computer, peripherals, I/O ports, connecting cables
- To demonstrate configuring the system as Dual boot both Windows and other Operating Systems Viz. Linux, BOSS
- To teach basic command line interface commands on Linux.
- To teach the usage of Internet for productivity and self-paced life-long learning
- To introduce Compression, Multimedia and Antivirus tools and Office Tools such as Word processors, Spread sheets and Presentation tools.

**Course Outcomes:**

- CO1: Perform Hardware troubleshooting.
- CO2: Understand Hardware components and inter dependencies.
- CO3: Safeguard computer systems from viruses/worms.
- CO4: Document/ Presentation preparation.
- CO5: Perform calculations using spreadsheets.

**PC Hardware & Software Installation**

**Task 1:** Identify the peripherals of a computer, components in a CPU and its functions. Draw the block diagram of the CPU along with the configuration of each peripheral and submit to your instructor.

**Task 2:** Every student should disassemble and assemble the PC back to working condition. Lab instructors should verify the work and follow it up with a Viva. Also students need to go through the video which shows the process of assembling a PC. A video would be given as part of the course content.

**Task 3:** Every student should individually install MS windows on the personal computer. Lab instructor should verify the installation and follow it up with a Viva.

**Task 4:** Every student should install Linux on the computer. This computer should have windows installed. The system should be configured as dual boot (VMWare) with both Windows and Linux. Lab instructors should verify the installation and follow it up with a Viva

**Task 5:** Every student should install BOSS on the computer. The system should be configured as dual boot (VMWare) with both Windows and BOSS. Lab instructors should verify the installation and follow it up with a Viva

**Internet & World Wide Web**

**Task1:** Orientation & Connectivity Boot Camp: Students should get connected to their Local Area Network and access the Internet. In the process they configure the TCP/IP setting. Finally, students should demonstrate, to the instructor, how to access the websites and email. If there is no internet connectivity preparations need to be made by the instructors to simulate the WWW on the LAN.

**Task 2:** Web Browsers, Surfing the Web: Students customize their web browsers with the LAN proxy settings, bookmarks, search toolbars and pop up blockers. Also, plug-ins like Macromedia Flash and JRE for applets should be configured.



**Task 3:** Search Engines & Netiquette: Students should know what search engines are and how to use the search engines. A few topics would be given to the students for which they need to search on Google. This should be demonstrated to the instructors by the student.

**Task 4:** Cyber Hygiene: Students would be exposed to the various threats on the internet and would be asked to configure their computer to be safe on the internet. They need to customize their browsers to block pop ups, block active x downloads to avoid viruses and/or worms.

### **LaTeX and WORD**

**Task 1 – Word Orientation:** The mentor needs to give an overview of La TeX and Microsoft (MS) office or equivalent (FOSS) tool word: Importance of La TeX and MS office or equivalent (FOSS) tool Word as word Processors, Details of the four tasks and features that would be covered in each, Using La TeX and word – Accessing, overview of toolbars, saving files, Using help and resources, rulers, format painter in word.

**Task 2:** Using La TeX and Word to create a project certificate. Features to be covered:-Formatting Fonts in word, Drop Cap in word, Applying Text effects, Using Character Spacing, Borders and Colors, Inserting Header and Footer, Using Date and Time option in both La TeX and Word.

**Task 3:** Creating project abstract Features to be covered:-Formatting Styles, Inserting table, Bullets and Numbering, Changing Text Direction, Cell alignment, Footnote, Hyperlink, Symbols, Spell Check, Track Changes.

**Task 4:** Creating a Newsletter: Features to be covered:- Table of Content, Newspaper columns, Images from files and clipart, Drawing toolbar and Word Art, Formatting Images, Textboxes, Paragraphs and Mail Merge in word.

### **EXCEL**

**Excel Orientation:** The mentor needs to tell the importance of MS office or equivalent (FOSS) tool Excel as a Spreadsheet tool, give the details of the four tasks and features that would be covered in each. Using Excel – Accessing, overview of toolbars, saving excel files, Using help and resources.

**Task 1:** Creating a Scheduler - Features to be covered: Gridlines, Format Cells, Summation, auto fill, Formatting Text

**Task 2:** Calculating GPA -. Features to be covered:- Cell Referencing, Formulae in excel – average, std. deviation, Charts, Renaming and Inserting worksheets, Hyper linking, Count function,

### **LOOKUP/VLOOKUP**

**Task 3:** Split cells, freeze panes, group and outline, Sorting, Boolean and logical operators, Conditional formatting

### **POWER POINT**

**Task 1:** Students will be working on basic power point utilities and tools which help them create basic power point presentations. PPT Orientation, Slide Layouts, Inserting Text, Word Art, Formatting Text, Bullets and Numbering, Auto Shapes, Lines and Arrows in PowerPoint.

**Task 2:** Interactive presentations - Hyperlinks, Inserting –Images, Clip Art, Audio, Video, Objects, Tables and Charts.

**Task 3:** Master Layouts (slide, template, and notes), Types of views (basic, presentation, slide slotter, notes etc), and Inserting – Background, textures, Design Templates, Hidden slides.



### AI TOOLS – ChatGPT

**Task 1:** Prompt Engineering: Experiment with different types of prompts to see how the model responds. Try asking questions, starting conversations, or even providing incomplete sentences to see how the model completes them.

- Ex: Prompt: "You are a knowledgeable AI. Please answer the following question: What is the capital of France?"

**Task 2:** Creative Writing: Use the model as a writing assistant. Provide the beginning of a story or a description of a scene, and let the model generate the rest of the content. This can be a fun way to brainstorm creative ideas

- Ex: Prompt: "In a world where gravity suddenly stopped working, people started floating upwards. Write a story about how society adapted to this new reality."

**Task 3:** Language Translation: Experiment with translation tasks by providing a sentence in one language and asking the model to translate it into another language. Compare the output to see how accurate and fluent the translations are.

- Ex: Prompt: "Translate the following English sentence to French: 'Hello, how are you doing today?'"

### Reference Books:

1. Comdex Information Technology course tool kit, Vikas Gupta, WILEY Dream tech, 2003
2. The Complete Computer upgrade and repair book, Cheryl A Schmidt, WILEY Dream tech, 2013, 3rd edition
3. Introduction to Information Technology, ITL Education Solutions limited, Pearson Education, 2012, 2<sup>nd</sup> edition
4. PC Hardware - A Handbook, Kate J. Chase, PHI (Microsoft)
5. LaTeX Companion, Leslie Lamport, PHI/Pearson.
6. IT Essentials PC Hardware and Software Companion Guide, David Anfinson and Ken Quamme. – CISCO Press, Pearson Education, 3<sup>rd</sup> edition
7. IT Essentials PC Hardware and Software Labs and Study Guide, Patrick Regan– CISCO Press, Pearson Education, 3<sup>rd</sup> edition



**R23BS03-P**

L	T	P	C
0	0	2	1

**ENGINEERING PHYSICS LAB**  
**(Common to All Branches of Engineering)**

**Course Objectives:**

To study the concepts of optical phenomenon like interference, diffraction etc., recognize the importance of energy gap in the study of conductivity and Hall effect in semiconductors and study the parameters and applications of dielectric and magnetic materials by conducting experiments.

**Course Outcomes:** The students will be able to

CO1: Operate optical instruments like travelling microscope and spectrometer.

CO2: Estimate the wavelengths of different colours using diffraction grating.

CO3: Plot the intensity of the magnetic field of circular coil carrying current with distance.

CO4: Evaluate dielectric constant and magnetic susceptibility for dielectric and magnetic materials respectively.

CO5: Calculate the band gap of a given semiconductor.

CO6: Identify the type of semiconductor using Hall effect.

**List of Experiments:**

1. Determination of radius of curvature of a given Plano-convex lens by Newton's rings.
2. Determination of wavelengths of different spectral lines in mercury spectrum using diffraction grating in normal incidence configuration.
3. Verification of Brewster's law
4. Determination of dielectric constant using charging and discharging method.
5. Study the variation of B versus H by magnetizing the magnetic material (B-H curve).
6. Determination of wavelength of Laser light using diffraction grating.
7. Estimation of Planck's constant using photoelectric effect.
8. Determination of the resistivity of semiconductors by four probe methods.
9. Determination of energy gap of a semiconductor using p-n junction diode.
10. Magnetic field along the axis of a current carrying circular coil by Stewart Gee's Method.
11. Determination of Hall voltage and Hall coefficient of a given semiconductor using Hall effect.
12. Determination of temperature coefficients of a thermistor.
13. Determination of acceleration due to gravity and radius of Gyration by using a compound pendulum.
14. Determination of magnetic susceptibility by Kundt's tube method.
15. Determination of rigidity modulus of the material of the given wire using Torsional pendulum.
16. Sonometer: Verification of laws of stretched string.
17. Determination of young's modulus for the given material of wooden scale by non-uniform bending (or double cantilever) method.
18. Determination of Frequency of electrically maintained tuning fork by Melde's experiment.

**Note:** Any TEN of the listed experiments are to be conducted. Out of which any TWO experiments may be conducted in virtual mode.

**References:**

A Textbook of Practical Physics - S. Balasubramanian, M.N. Srinivasan, S. Chand Publishers, 2017.



**R23ES05-P**

L	T	P	C
0	0	3	1.5

**ELECTRICAL & ELECTRONICS ENGINEERING WORKSHOP**

(Common to All branches of Engineering)

**Course Objectives:**

To impart knowledge on the fundamental laws & theorems of electrical circuits, functions of electrical machines and energy calculations.

**Course Outcomes:**

**CO1:** Understand the Electrical circuit design concept; measurement of resistance, power, power factor; concept of wiring and operation of Electrical Machines and Transformer.

**CO2:** Apply the theoretical concepts and operating principles to derive mathematical models for circuits, Electrical machines and measuring instruments; calculations for the measurement of resistance, power and power factor.

**CO3:** Apply the theoretical concepts to obtain calculations for the measurement of resistance, power and power factor.

**CO4:** Analyse various characteristics of electrical circuits, electrical machines and measuring instruments.

**CO5:** Design suitable circuits and methodologies for the measurement of various electrical parameters; Household and commercial wiring.

**Activities:**

1. Familiarization of commonly used Electrical & Electronic Workshop Tools: Bread board, Solder, cables, relays, switches, connectors, fuses, Cutter, plier, screwdriver set, wire stripper, flux, knife/blade, soldering iron, de-soldering pump etc.
  - Provide some exercises so that hardware tools and instruments are learned to be used by the students.
2. Familiarization of Measuring Instruments like Voltmeters, Ammeters, multimeter, LCR-Q meter, Power Supplies, CRO, DSO, Function Generator, Frequency counter.
  - Provide some exercises so that measuring instruments are learned to be used by the students.
3. Components:
  - Familiarization/Identification of components (Resistors, Capacitors, Inductors, Diodes, transistors, IC's etc.) – Functionality, type, size, colour coding package, symbol, cost etc.
4. Testing of components like Resistor, Capacitor, Diode, Transistor, ICs etc. - Compare values of components like resistors, inductors, capacitors etc with the measured values by using instruments



## PART A: ELECTRICAL ENGINEERING LAB

### List of experiments:

1. Verification of KCL and KVL
2. Verification of Superposition theorem
3. Measurement of Resistance using Wheat stone bridge
4. Magnetization Characteristics of DC shunt Generator
5. Measurement of Power and Power factor using Single-phase wattmeter
6. Measurement of Earth Resistance using Megger
7. Calculation of Electrical Energy for Domestic Premises

### Reference Books:

1. Basic Electrical Engineering, D. C. Kulshreshtha, Tata McGraw Hill, 2019, First Edition
2. Power System Engineering, P.V. Gupta, M.L. Soni, U.S. Bhatnagar and A. Chakrabarti, Dhanpat Rai & Co, 2013
3. Fundamentals of Electrical Engineering, Rajendra Prasad, PHI publishers, 2014, Third Edition

**Note:** Minimum Six Experiments to be performed.

## PART B: ELECTRONICS ENGINEERING LAB

### Course Objectives:

- To impart knowledge on the principles of digital electronics and fundamentals of electron devices & its applications.

**Course Outcomes:** At the end of the course, the student will be able to

- CO1: Identify & testing of various electronic components.  
CO2: Understand the usage of electronic measuring instruments.  
CO3: Plot and discuss the characteristics of various electron devices.  
CO4: Explain the operation of a digital circuit.

### List of Experiments:

1. Plot V-I characteristics of PN Junction diode A) Forward bias B) **Reverse** bias.
2. Plot V – I characteristics of Zener Diode and its application as voltage Regulator.
3. Implementation of half wave and full wave rectifiers
4. Plot Input & Output characteristics of BJT in CE and CB configurations
5. Frequency response of CE amplifier.
6. Simulation of RC coupled amplifier with the design supplied
7. Verification of Truth Table of AND, OR, NOT, NAND, NOR, Ex-OR, Ex-NOR gates using ICs.
8. Verification of Truth Tables of S-R, J-K& D flip flops using respective ICs.

Tools / Equipment Required: DC Power supplies, Multi meters, DC Ammeters, DC Voltmeters, AC Voltmeters, CROs, all the required active devices.



**References:**

1. R. L. Boylestad & Louis Nashlesky, Electronic Devices & Circuit Theory, Pearson Education, 2021.
2. R. P. Jain, Modern Digital Electronics, 4<sup>th</sup> Edition, Tata Mc Graw Hill, 2009
3. R. T. Paynter, Introductory Electronic Devices & Circuits – Conventional Flow Version, Pearson Education, 2009.

Note: Minimum Six Experiments to be performed. All the experiments shall be implemented using both Hardware and Software.



**R23PC04-P**

L	T	P	C
0	0	3	1.5

**NETWORK ANALYSIS AND SIMULATION LABORATORY**  
(ECE & EIE)

**Course Objectives:**

- To gain hands on experience in verifying Kirchoff’s laws and network theorems
- To analyze transient behavior of circuits
- To study resonance characteristics
- To determine 2-port network parameters

**Course Outcomes:**

- CO1: Verify Kirchoff’s laws and network theorems.  
 CO2: Measure time constants of RL & RC circuits.  
 CO3: Analyze behavior of RLC circuit for different cases.  
 CO4: Design resonant circuit for given specifications.  
 CO5: Characterize and model the network in terms of all network parameters.

The following experiments need to be performed using both Hardware and simulation Software.

The experiments need to be simulated using software and the same need to be verified using the hardware.

1. Study of components of a circuit and Verification of KCL and KVL.
2. Verification of mesh and nodal analysis for AC circuits
3. Verification of Superposition, Thevenin’s & Norton theorems for AC circuits
4. Verification of maximum power transfer theorem for AC circuits
5. Verification of Tellegen’s theorem for two networks of the same topology.
6. Study of DC transients in RL, RC and RLC circuits
7. To study frequency response of various 1<sup>st</sup> order RL & RC networks
8. To study the transient and steady state response of a 2<sup>nd</sup> order circuit by varying its various parameters and studying their effects on responses
9. Find the Q Factor and Bandwidth of a Series and Parallel Resonance circuit.
10. Determination of open circuit (Z) and short circuit (Y) parameters
11. Determination of hybrid (H) and transmission (ABCD) parameters
12. To measure two port parameters of a twin-T network and study its frequency response.

**Hardware Requirements:**

Regulated Power supplies, Analog/Digital Function Generators, Digital Multimeters, Decade Resistance Boxes/Rheostats, Decade Capacitance Boxes, Ammeters (Analog or Digital), Voltmeters (Analog or Digital), Active & Passive Electronic Component

**Software requirements:**

Multisim/ Pspice/Equivalent simulation software tool, Computer Systems with required specifications

**References:**

1. Network Analysis – ME Van Valkenburg, Prentice Hall of India, revised 3rd Edition, 2019.
2. Engineering Circuit Analysis by William H. Hayt, Jack Kemmerly, Jamie Phillips, Steven M. Durbin, 9<sup>th</sup> Edition 2020.



**R23MC02**

L	T	P	C
0	0	1	0.5

**NSS/NCC/SCOUTS & GUIDES/COMMUNITY SERVICE  
(Common to All branches of Engineering)**

**Course Objectives:**

The objective of introducing this course is to impart discipline, character, fraternity, teamwork, social consciousness among the students and engaging them in selfless service.

**Course Outcomes:**

After completion of the course the students will be able to

- CO1:** Understand the importance of discipline, character and service motto.
- CO2:** Solve some societal issues by applying acquired knowledge, facts, and techniques.
- CO3:** Explore human relationships by analyzing social problems.
- CO4:** Determine to extend their help for the fellow beings and downtrodden people.
- CO5:** Develop leadership skills and civic responsibilities.

**UNIT I Orientation**

General Orientation on NSS/NCC/ Scouts & Guides/Community Service activities, career guidance.

**Activities:**

- i) Conducting –ice breaking sessions-expectations from the course-knowing personal talents and skills
- ii) Conducting orientations programs for the students –future plans-activities-releasing road map etc.
- iii) Displaying success stories-motivational biopics- award winning movies on societal issues etc.
- iv) Conducting talent show in singing patriotic songs-paintings- any other contribution.

**UNIT II Nature & Care**

**Activities:**

- i) Best out of waste competition.
- ii) Poster and signs making competition to spread environmental awareness.
- iii) Recycling and environmental pollution article writing competition.
- iv) Organising Zero-waste day.
- v) Digital Environmental awareness activity via various social media platforms.
- vi) Virtual demonstration of different eco-friendly approaches for sustainable living.
- vii) Write a summary on any book related to environmental issues.

**UNIT III Community Service**

**Activities:**

- i) Conducting One Day Special Camp in a village contacting village-area leaders- Survey in the village, identification of problems- helping them to solve via media- authorities-experts-etc.
- ii) Conducting awareness programs on Health-related issues such as General Health, Mental health, Spiritual Health, HIV/AIDS,
- iii) Conducting consumer Awareness. Explaining various legal provisions etc.
- iv) Women Empowerment Programmes- Sexual Abuse, Adolescent Health and Population Education.



- v) Any other programmes in collaboration with local charities, NGOs etc.

**Reference Books:**

1. Nirmalya Kumar Sinha & Surajit Majumder, *A Text Book of National Service Scheme Vol;I*, Vidya Kutir Publication, 2021 ( ISBN 978-81-952368-8-6)
2. *Red Book - National Cadet Corps – Standing Instructions Vol I & II*, Directorate General of NCC, Ministry of Defence, New Delhi
3. Davis M. L. and Cornwell D. A., “Introduction to Environmental Engineering”, McGraw Hill, New York 4/e 2008
4. Masters G. M., Joseph K. and Nagendran R. “Introduction to Environmental Engineering and Science”, Pearson Education, New Delhi. 2/e 2007
5. Ram Ahuja. *Social Problems in India*, Rawat Publications, New Delhi.

**General Guidelines:**

1. Institutes must assign slots in the Timetable for the activities.
2. Institutes are required to provide instructor to mentor the students.

**Evaluation Guidelines:**

- Evaluated for a total of 100 marks.
- A student can select 6 activities of his/her choice with a minimum of 01 activity per unit. Each activity shall be evaluated by the concerned teacher for 15 marks, totalling to 90 marks.
- A student shall be evaluated by the concerned teacher for 10 marks by conducting viva voce on the subject.



**ADIKAVI NANNAYA UNIVERSITY**

**AKNU COLLEGE OF ENGINEERING  
RAJAMAHENDRAVARAM**

**DEPARTMENT OF SCIENCE & HUMANITIES**

**I B.Tech**

**(Electronics and Instrumentation Engineering)**

**MODEL QUESTION PAPERS**

**(w.e.f. AY 2023-24 - as per R23 Regulations)**

**BOARD OF STUDIES  
AKNU COLLEGE OF ENGINEERING**

**I B. Tech I Semester Regular Examinations, DEC/JAN – 2023**

**COMMUNICATIVE ENGLISH**

**(MODEL QUESTION PAPER)**

**(Common to all Branches)**

**Time: 3hrs**

**Max. Marks: 70**

---

Note: 1. Question Paper consists of two parts (**Part-A** and **Part-B**)

**PART– A**

**Answer ALL Questions.**

**10x 2 = 20M**

**I. Answer the following ten questions. Each question carries 2 marks.**

- a) Define the term "homographs."
- b) Explain the concept of skimming in reading.
- c) Provide an example of a compound word.
- d) What is the main focus of the lesson "The Brook" by Alfred Tennyson?
- e) Name two mechanics of writing that involve punctuation.
- f) Discuss the role of listening in the comprehension of global ideas.
- g) How can graphic elements in texts aid in conveying information?
- h) Define intrapersonal communication.
- i) Identify one type of cohesive device used in paragraph writing.
- j) Briefly explain the concept of collocations.

**PART-B**

**II. Each question carries 10 Marks**

**5x 10 = 50M**

2. a) Discuss the significance of the title *Gift of the Magi*.

OR

b) Discuss the significance of root words in expanding vocabulary with examples.

3. a) Discuss the verbal techniques used in the poem "The Brook" by Alfred Tennyson.

OR

b) What are homonyms? How are they classified. Provide examples with meanings.

4. a) Summarize the key points discussed in the biography of Elon Musk.

OR

b) Explain the rules of subject-verb agreement.

5. a) Analyze the use of graphic elements in "The Toys of Peace" by Saki.

OR

b) Demonstrate the differences between active and passive voice with examples.

6. a) Define interpersonal communication and explain its significance for career development.

OR

b) Discuss the importance of proper capitalization in writing.

## I B. Tech I Semester Regular Examinations, DEC/JAN – 2023

## LINEAR ALGEBRA AND CALCULUS

## (MODEL QUESTION PAPER)

(Common to all Branches)

Time: 3hrs

Max. Marks: 70

Note: 1. Question Paper consists of two parts (Part-A and Part-B)

## Part– A

Answer ALL Questions.

10x 2 = 20M

- 1) (a). Define Rank of a matrix with an example.
- (b). Define Consistency and Inconsistency of the system of linear equations.
- (c). State Cayley-Hamilton theorem with an example.
- (d). Write down the matrix of the quadratic form
- $$x_1^2 - 4x_1x_2 + 2x_2^2 + 8x_1x_3 - 7x_3^2 + 5x_2x_3.$$
- (e). State Rolle's theorem.
- (f). Verify Lagrange's mean value theorem for the function  $f(x) = \sin x$  in  $[0, \pi]$  and determine  $c$  lying in  $0$  and  $\pi$
- (g). Write Euler's theorem on homogeneous function.
- (h). Find the Jacobian of the functions,  $u = \frac{x^2 - y^2}{x^2 + y^2}$ ,  $v = \frac{2xy}{x^2 + y^2}$ .
- (i). Evaluate  $\int_1^2 \int_3^5 xy \, dx dy$
- (j). Evaluate  $\int_0^1 \int_{y^2}^1 \int_0^{1-x} x dx dy dz$

**Part – B**

**5x10=50**

2) a). Reduce the following matrix into its normal form and hence find its rank.

$$\begin{bmatrix} 2 & 3 & -1 & -1 \\ 1 & -1 & -2 & -4 \\ 3 & 1 & 3 & -2 \\ 6 & 3 & 0 & -7 \end{bmatrix}$$

(OR)

b). Test for consistency and solve

$$2x - 3y + 7z = 5, 3x + y - 3z = 13, 2x + 19y - 47z = 32$$

3. a). Find the eigen values and eigen vectors of  $\begin{bmatrix} -2 & 2 & -3 \\ 2 & 1 & -6 \\ -1 & -2 & 0 \end{bmatrix}$

(OR)

b). Reduce the quadratic form  $x_1^2 + 3x_2^2 + 3x_3^2 - 2x_2x_3$  into canonical form and hence find rank and write the nature.

4 a). Verify Rolle`s theorem for  $f(x) = (x+2)^3(x-3)^4$  in  $(-2,3)$  (if  $0 < a < b < 1$ )

(OR)

b). Using Taylor`s theorem prove that  $x - \frac{x^3}{6} < \sin x < x - \frac{x^3}{6} + \frac{x^5}{120}$ , for  $x > 0$

5 a). If  $u = \tan^{-1}\left(\frac{x^3 + y^3}{x + y}\right)$ , prove that  $x \frac{\partial u}{\partial x} + y \frac{\partial u}{\partial y} = \sin 2u$

(OR)

b). Find the maximum and minimum values of  $x^3 + 3xy^2 - 15x^2 - 15y^2 + 72x$

6 a). Evaluate  $\int_0^1 \int_{e^x}^e \frac{dydx}{\log y}$  by changing the order of integration.

(OR)

b). Show that the area between the parabolas  $y^2 = 4ax$  and  $x^2 = 4ay$  is  $\frac{16}{3}a^2$ .



R23

Code No: R23BS05

I B. Tech I Semester Regular Examinations, DEC/JAN – 2023

**CHEMISTRY**  
**(MODEL QUESTION PAPER)**  
**(Common to CSE,ECE&EIE)**

**Time: 3hrs**

**Max. Marks: 70**

---

Note: 1. Question Paper consists of two parts (**Part-A** and **Part-B**)

**PART- A**

**I. Answer ALL Questions.**

**2x 10 = 20M**

- a. Write the Schrodinger Wave equation
- b. What is particle in one dimensional box
- c. What is Electromagnetic spectrum?
- d. What are super capacitors?
- e. What are the WHO standards for drinking water?
- f. What is meant by Functionality?
- g. What are electro chemical sensors?
- h. What are semiconductors and types?
- i. Mention two applications of Nano materials?
- j. Define Beer Lamberts law?

**PART-B**

**II. Each question carries 10 Marks**

**5x 10 = 50M**

2. a) Explain semiconductors, types and its applications.

OR

b) Enumerate the properties and applications of fullerenes.

3. a) Differentiate between thermosetting and thermoplastics with suitable examples and mention their uses.

OR

b) Discuss the preparation, properties and uses of Bakelite and PVC.

4. a) Discuss the uses of electrochemical series and Explain the Nernst equation  
OR  
b) What are Primary and secondary cells? Explain with types and examples
5. a) Write the significance of Schrodinger Wave Equation and mention particle in one dimensional box.  
OR  
b) Discuss the energy level diagrams of O<sub>2</sub> and CO and mention Pi molecular orbitals of butadiene.
6. a) Explain the basic principal of chromatography and write the classification of HPLC instrumentation.  
OR  
b) What is electromagnetic spectrum? Explain UV Visible spectroscopy with electronic transmission.

**I B. Tech I Semester Regular Examinations, DEC/JAN – 2023**  
**BASIC CIVIL & MECHANICAL ENGINEERING**  
(Common to All Branches of Engineering)

Time: 3 hours

Max. Marks: 35

- Note: 1. Question Paper consists of two parts (**Part-A** and **Part-B**)  
2. Answering the question in **Part-A** is Compulsory  
3. Answer all Questions from **Part-B**
- ~~~~~

**PART – A**

1. a) What is the Role of Mechanical Engineering in Industries and Society? [1M]
- b) What is Smart manufacturing and some Examples? [1M]
- c) What is the difference between 2-Stroke and 4-Stroke engines? [1M]
- d) Define Belt drive? [1M]
- e) What is meant by CNC machine? [1M]

**PART – B**

2. a) Explain the Role of Mechanical Engineering in Industries and Society? [6M]
- b) Explain different Engineering Materials? [4M]
- (OR)
- c) Explain Emerging Technologies in various Engineering fields? [10M]
  
3. a) Explain Casting Process with neat diagrams? [5M]
- b) Explain Working Principle of Boilers? [5M]
- (OR)
- c) Explain briefly 3D-printing & smart manufacturing? [6M]
- d) ) Explain briefly Otto cycle, Diesel cycle ? [4M]
  
4. a) Explain working Principle of Steam power plant with neat diagram? [7M]
- b) Write a short note on Gear drives and their applications? [3M]
- (OR)
- c) Explain working Principle of Nuclear power plant with neat diagram? [7M]
- d) Write a short note on Robotics and their applications? [3M]



**I B. Tech I Sem MODEL QUESTION PAPER**  
**BASIC CIVIL AND MECHANICAL ENGINEERING**

(Common to All Branches of Engineering)

Time: 3 hours

Max. Marks: 70

**PART –A**

**35 Marks**

- Note: 1. First question consists of five questions each question carries one mark  
2. Questions from 2 to 4, there shall be either/or type questions of marks,  
Student should answer any one of them.
- ~~~~~

Answer all the questions, each question carries one mark

1. a) Define coarse aggregate and fine aggregate? [1M]  
b) Define contour? [1M]  
c) Write a short note on various types of pavement? [1M]  
d) Define hydrology? [1M]  
e) List out the different types of dams? [1M]
  
2. a) Explain briefly about role of civil Engineering in society? [5M]  
b) What are the various tests conducted on bricks. Explain any one briefly? [5M]  
(or)  
c) What are the various field and laboratory tests conducted on cement? [10M]
  
3. a) Explain briefly about horizontal measurements? [5M]  
b) Write the objectives of surveying? [5M]  
(or)  
c) Following consecutive staffs reading were taken with a level along a sloping ground line XY at regular intervals of 20m by using 4m levelling staff 0.352, 0.787, 1.832, 2.956, 3.758, 0.953, 1.766, 2.738, 3.872, 0.812, 2.325 and 3.137. Rule out a page of level field book, enter the reading RL of point X is 120.280. Calculate RL of all points by Height of Instrument Method, and workout the gradient of line XY? [10M]
  
4. a) Explain briefly about various rainwater harvesting techniques used in urban and rural areas. [10M]  
(or)  
b) Explain briefly about various sources of water? [5M]  
c) Write a short note on quality of water? [5M]

**I B. Tech I Semester Regular Examinations, DEC/JAN – 2023**

**INTRODUCTION TO PROGRAMMING**

**(MODEL QUESTION PAPER)**

**(Common to all Branches)**

**Time: 3hrs**

**Max. Marks: 70**

---

Note: 1. Question Paper consists of two parts (**Part-A** and **Part-B**)

~~~~~

**PART- A**

**I. Answer ALL Questions.**

**10x 2 = 20M**

- (a) What is the difference between low level and high level language and uses of them?
- (b) What is the difference between assignment and equality operation?
- (c) Explain pre- and post- decrement and increment operation on a variable with an example.
- (d) Write the differences between nested if( ) statement and switch( ) statement.
- (e) What are the differences between recursion and iteration?
- (f) What is difference between while and do-while loops?
- (g) What are the uses of functions in C language?
- (h) What is an array variable? How it is different from ordinary variable?
- (i) Write the differences between structure and union.
- (j) What is the use of fseek( ) function in files. Write its syntax?

**PART-B**

**II. Each question carries 10 Marks**

**5x 10 = 50M**

- 1. a) How are negative values stored in the memory in C programming? Explain.

- b) What is a constant? How is it different from a variable? Justify with suitable Example.

**OR**

2. a) What do you mean by Formatted Input? Explain in detail the prototype of 'scanf' function in C programming, including its argument list and return type.
- b) How the precedence and Associativity rules of operators help in executing a 'C' expression? Explain with an example.
3. a) Write a C program to find sum of following series where the value of N is taken as input  
 $1 + 1/2 + 1/3 + 1/4 + 1/5 + \dots + 1/N$
- b) Is 'break' needed in every case of switch statement? Give explanation.

**OR**

4. a) What are Control statements? Explain about the various Control statements in C programming.
- b) What is the output of the following C code? Give Explanation.
- ```
#include <stdio.h>
int main ()
{
int a = 1, b = 2, c = 3;
if (c > b > a)
printf("TRUE");
else
printf("FALSE");
return 0;
}
```
5. a) Explain the differences between Structures and Unions in C language. And demonstrate the memory allocation strategy for Unions and Structures in C programming.
- b) Write a C program to print Largest and Smallest Word from a given sentence. If there are two or more words of same length, then the first one is considered. A single letter in the sentence is also consider as a word.

**OR**

6. a) Explain the memory representation of one- and two-dimensional arrays in C programming with neat diagrams.
- b) Write the syntax to define Union? List out the advantages and disadvantages of using Unions.
7. a) What is the main use of function pointer in C? How do you declare a function pointer? Explain.
- b) Write a C program to access the values of an array of characters using pointer.

**OR**

8. a) Explain in detail about the types of C preprocessor directives.
- c) Assume size of an integer and a pointer is 2 byte. Find the output of the following C code and also give Explanation.

```
#include <stdio.h>
#define A 5
#define B 7
int main ()
{
int (*x)[A][B];
printf(“%d”, sizeof(*x));
return 0;
}
```

- 9.s a) pass an array to a function in C programming? Explain.

How to

- b) Write a C program to generate Fibonacci series using recursive functions.

**OR**

10. a) Illustrate the functions for character input and output in C programming.
- b) Explain the following file handling functions in C programming

**i)** fopen()

**ii)** fseek()

**iii)** fwrite()

R23

Code No: R23BS03

**I B. Tech I Semester Regular Examinations, DEC/JAN – 2023**  
**ENGINEERING PHYSICS**  
**(MODEL QUESTION PAPER)**  
**(Common to all Branches)**

**Time: 3hrs**

**Max. Marks: 70**

Note: 1. Question Paper consists of two parts (**Part-A** and **Part-B**)  
~~~~~

**PART- A**

**Answer ALL Questions.**

**10x 2 = 20M**

**I. Answer the following ten questions. Each question carries 2 marks.**

- Why two different light sources can't act as coherent sources?
- Why diffraction of light is not evident in daily life?
- Define O-ray and E-ray.
- How is laser different from an ordinary light?
- What is reverberation time?
- Draw (110) & (211) planes in a cubic crystal.
- Why magnetic susceptibility of diamagnetic materials is negative?
- Define Bragg's Law.
- Draw and Label the Hysteresis curve.
- Write a note on Fermi Dirac Distribution.

**1. PART-B**

**II. Each question carries 10 Marks**

**5x 10 = 50M**

- Explain the formation of Newton's rings and derive the expression for diameter of the dark rings in the reflected light. Also show that rings are not equally spaced.
  - In a Newton's rings experiment, the diameters of 5<sup>th</sup> and 15<sup>th</sup> dark rings are 0.336cm and 0.59cm respectively. If the radius of curvature of plano-convex lens is 100cm, find the wavelength of monochromatic light. What happens to ring diameters if air film is replaced with liquid of refractive index 1.33.

OR

- c) Explain the Fraunhofer diffraction due to single slit. Obtain the conditions for maxima and minima. (6M)
  - d) In the diffraction grating, what is effect of total number of lines and width of grating on the spectrum. (4M)
3. a) Calculate Packing Fraction of SC, BCC, FCC. (6M)
- b) How you determine the Crystal Structure using Laue's Method. (4M)

OR

- c) Explain Space lattice, Basis, Unit Cell, Lattice Parameters, Coordination number, packing fraction. (7M)
- d) Explain Miller Indices importance. (3M)

4. a) Explain Lorentz internal field with the base of Dielectric polarization. (6M)
- b) Deduce Clausius Mossotti equation. (4M)

OR

- c) Explain Atomic origin of Magnetism. (6M)
- d) Explain Soft and Hard magnetic Materials (4M)

5. a) Deduce Schrodinger Time dependent Equation. (7M)
- b) Write a note on density of states (3M)

OR

- c) Explain Dual Nature of Matter, Heisenberg's Uncertainty Principle, and wave function. (6M)
- d) Present the merits and Demerits of Classical field electron theory. (4M)

6. a) Deduce an equation for carrier concentration of Intrinsic semiconductors. (7M)
- b) What is Hall Effect (3M)

OR

- c) Deduce equation for Electrical Conductivity of an intrinsic semiconductor. (6M)
- d) Explain Drift and Diffusion of currents. (4)

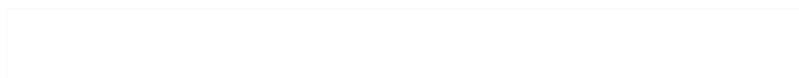



Code No: R23BS02

I B. Tech I Semester Regular Examinations, DEC/JAN – 2023

DIFFERENTIAL EQUATIONS AND VECTOR ANALYSIS

(MODEL QUESTION PAPER)

(Common to all Branches)

Time: 3hrs

Max. Marks: 70

Note: 1. Question Paper consists of two parts (Part-A and Part-B)

**Part– A****Answer ALL Questions.****2x 10 = 20M**

- 1) (a). Solve  $(3x^2 + 6xy^2)dx + (6x^2y + 4y^3)dy = 0$ .
- (b). State Newton's Law of cooling
- (c). Solve  $\frac{d^3y}{dx^3} - 3\frac{d^2y}{dx^2} + 3\frac{dy}{dx} - y = 0$
- (d). Find the P.I of  $(D^2 - 5D + 6)y = e^{4x}$ .
- (e). Solve  $xp + yq = z$ .
- (f). From the partial differential equation by eliminating arbitrary constants from  $z = ax + by$ .
- (g). Find grad  $\phi$  where  $\phi = x^3 + y^3 + 3xyz$  at  $(1, 1, -2)$ .
- (h). Find the angle between the surfaces  $x^2 + y^2 + z^2 = 9$  and  $z = x^2 + y^2 - 3$  at the point  $(2, -1, 2)$ .
- (i). State Green's Theorem
- (j). Evaluate by Stokes theorem  $\int_c (yzdx + zxdy + xydz)$  where  $c$  is the curve  
 $x^2 + y^2 = 1, z = y^2$

**Part – B**

**5x10=50**

2. a). Solve  $\frac{dy}{dx} - \frac{y}{x+1} = e^{3x}(x+1)$

(OR)

b). If the air is maintained at  $30^{\circ}C$  and the temperature of the body cools from  $80^{\circ}C$  to  $60^{\circ}C$  in 12 minutes, find the temperature of the body after 24 minutes.

3. a). Solve  $\frac{d^2y}{dx^2} + 3\frac{dy}{dx} + 2y = 4\cos^2 x$

(OR)

b). Use the method of Variation of parameters  $\frac{d^2y}{dx^2} + 4y = \tan 2x$

4 a) Solve  $(x^2 - yz)p + (y^2 - zx)q = (z^2 - xy)$ .

(OR)

b) Solve  $(D^2 - 4DD' + 4D'^2)z = e^{2x+y}$ .

5. a). If  $u = x + y + z, v = x^2 + y^2 + z^2, w = xy + yz + zx$  prove that  $[gradu, gradv, gradw] = 0$

(OR)

b). Show that  $\nabla^2(r^n) = n(n+1)r^{n-2}$

6 a). Compute the line integral  $\int_c (y^2 dx - x^2 dy)$  about the triangle whose vertices are (1,0), (0,1) and (-1,0).

(OR)

b). Verify Greens theorem for  $\int_c [(xy + y^2) dx + x^2 dy]$  where c is bounded by  $y=x$  and  $y=x^2$

**I B. Tech I Semester Regular Examinations, DEC/JAN – 2023**  
**BASIC ELECTRICAL & ELECTRONICS ENGINEERING**  
(Com. To All Branches of Engineering)

Time: 3 hours

Max. Marks: 35

- Note: 1. Question Paper consists of two parts (**Part-A** and **Part-B**)  
2. Answering the question in **Part-A** is Compulsory  
3. Answer all Questions from **Part-B**
- ~~~~~

**PART – A**

1. a) Define Ohms law? [1M]
- b) Define amplitude, time period and frequency? [1M]
- c) What are the Applications of electrical machines? [1M]
- d) Define conventional Energy sources? [1M]
- e) Define unit for consumption of electrical energy? [1M]

**PART – B**

2. a) How the capacitors are connected in parallel and series and derive the expression for equivalent capacitance [10M]
- (OR)
- b) Define AC fundamentals and derive the expression for average value, RMS value, average power and RMS power? [10M]
3. a) Draw the construction of DC generator and explain briefly. [10M]
- (OR)
- b) Explain the construction and working of PMMC meter? [10M]
4. a) Draw and explain the layout and operation of hydel power generation [10M]
- (OR)
- b) Explain the working principle of fuse and miniature circuit breaker [10M]

**I B. Tech I Semester Regular Examinations, DEC/JAN – 2023**  
**BASIC ELECTRICAL & ELECTRONICS ENGINEERING**  
(Common to all Branches of Engineering)

Time: 3 hours

Max. Marks: 35

Note:

1. Question Paper consists of two parts (**Part-A** and **Part-B**)
  2. Answering the question in **Part-A** is Compulsory
  3. Answer all Questions from **Part-B**
- ~~~~~

**PART –A**

1. a) What is doping.? [1M]
- b) What is an Amplifier.? [1M]
- c) Define Bandwidth.? [1M]
- d) What is a logic gate.? [1M]
- e) What is combinational circuits.? [1M]

**PART –B**

2. a) What is Zener effect.? Draw and explain its characteristics [10M]
- (OR)
- b) What is BJT? Explain about CC configuration [10M]
3. a) Explain full wave rectifier (with & without) filter and draw the neat circuit diagram. [10M]
- (OR)
- b) Draw the block diagram of electronic instrumentation and explain each block? [10M]
4. a) What is a hamming code.? Explain with one example [10M]
- (OR)
- b) What are the basic logic gates.? Explain with truth tables [10M]

**I B. Tech I Semester Regular Examinations, DEC/JAN – 2023**  
**ENGINEERING GRAPHICS**  
**(MODEL QUESTION PAPER)**  
**(Common to CE&ME )**

**Time: 3hrs****Max. Marks: 70**

Note: 1. Question Paper consists of two parts (**Part-A** and **Part-B**)

~~~~~

**PART- A****I. Answer ALL Questions.****10x 2 = 20M**

- a) Print following in single stroke-vertical lettering of 10 mm size in capital letters:  
“ENGINEERING GRAPHICS
- b) Define involute?
- c) Construct a regular hexagon of 25 mm side using any method?
- d) What is meant by oblique plane?
- e) Define the term apparent angles of inclination in the projection of straight lines?
- f) What is representative fraction?
- g) What do you understand by a “Right Regular Prism”?
- h) Define the terms: Isometric axes, Isometric Planes.
- i) What is the difference between Frustum and Truncated?
- j) Define Isometric scale?

**PART-B****II. Each question carries 10 Marks****5x 10 = 50M**

2. a) Inscribe a regular Hexagon in a circle of 70mm diameter? [5M]
- b) The distance of the focus from the directrix is 65mm. Draw the locus of the point which moves such that its distance from the focus is equal to its distance from the directrix. Name the Curve. [5M]

OR

- c) A circle of 50 mm diameter rolls along a straight line without slipping. Draw the curve traced out by a point P on the circumference, for one complete revolution of the circle. Name the curve. Draw a tangent to the curve at a point on it 40 mm from the line.[6M]
  - d) Construct a diagonal scale of RF=1/3200000 to show kilometer and long enough to measure up to 400kM to show distances of 257kM and 333kM on your scale. [4M]
3. a) State the quadrants in which the following points are situated: [4M]
    - (i) A point P; its top view is 40 mm above xy; the front view, 20 mm below the top view.
    - (ii) A point Q, its projections coincide with each other 40 mm below xy.
  - b) A line AB, 90 mm long is inclined at 30° to the H.P. Its end A is 12 mm above the H.P. and 20 mm in front of the V.P.Its front view measures 65 mm. Draw the top view of AB and determine its inclination with the V.P. [6M]

OR

- c) The top view of a 75 mm long line AB measures 65 mm, while the length of its front view is 50 mm. It's one end A is in the H.P. and 12 mm in front of the V.P. Draw the projections of AB and determine its inclinations with the H.P. and the V.P. [5M]

- d) Draw the projections of a regular hexagon of 25 mm side, having one of its sides in the H.P. and inclined at  $60^\circ$  to the V.P., and its surface making an angle of  $45^\circ$  with the H.P. [5M]
4. a) Draw the projections of a cone, base 75 mm diameter and axis 100 mm long, lying on the H.P. on one of its generators with the axis parallel to the V.P. [10M]
- OR
- b) A hexagonal pyramid, base 25 mm side and axis 55 mm long, has one of its slant edges on the ground. A plane containing that edge and the axis is perpendicular to the H.P. and inclined at  $45^\circ$  to the V.P. Draw its projections when the apex is nearer the V.P. than the base. [10M]
5. a) A square prism, base 40 mm side, axis 80 mm long, has its base on the H.P. and its faces equally inclined to the V.P. It is cut by a plane, perpendicular to the V.P., inclined at  $60^\circ$  to the H.P. and passing through a point on the axis, 55 mm above the H.P. Draw its front view, sectional top view and another top view on an A.I.P. parallel to the section plane. [10M]

OR

- b) Draw the development of lateral surface of a square pyramid which is standing on HP with one of its base edges is parallel to VP. The base of square is 25 mm side and the height of the axis is 40 mm. [10M]
6. a) Draw (i) Front View (ii) Top View (iii) Side View [10M]

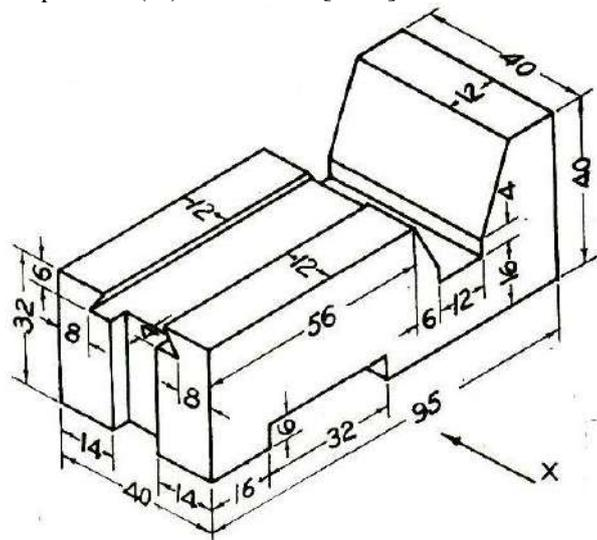

OR

- b) Draw three possible ways of representing the isometric projection of a hexagonal prism side of base 25mm & height 60mm. [10M]

**I B. Tech I Semester Regular Examinations, DEC/JAN – 2023**  
**NETWORK ANALYSIS**  
**(MODEL QUESTION PAPER)**  
**(Common to ECE & EIE)**

**Time: 3hrs**

**Max. Marks: 70**

---

Note: 1. Question Paper consists of two parts (**Part-A** and **Part-B**)  
~~~~~

**PART- A**

**I. Answer ALL Questions.**

**10x 2 = 20M**

- a) Explain about the Principal of Duality
- b) Define Thevenin's, Norton's.
- c) what is meant by transient response
- d) Distinguish between Laplace transform and Inverse Laplace transform
- e) What is complex impedance
- f) Define Bandwidth.
- g) Define Self-inductance and Series resonance.
- h) Write the relationship between Y-parameters and Z-parameters.
- i) What does a Two Port network represent

**PART-B**

**II. Each question carries 10 Marks**

**5x 10 = 50M**

- 2 a) Explain About the mesh and nodal analysis with neat diagram. [10M]

**OR**

- b) Determine the current through  $1\Omega$  resistor for the circuit shown in fig using Thevenin's theorem [10M]

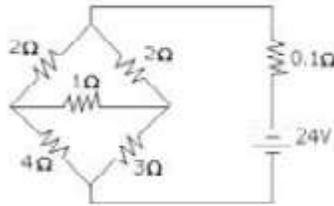

Figure

3 a) Explain and derive the second order differential equations [10M]

**OR**

b) Explain Moving Iron (MI) Instruments and Wheat Stone bridge. [10M]

4. a) In a series RLC circuit,  $R = 6\Omega$ ,  $L=1H$ , and  $c=1F$ . A dc voltage of 40 V is applied at  $t=0$ . Obtain  $i(t)$ . [10M]

**OR**

b) Find the effective resistance between P and Q by Star-Delta conversion as shown fig. [10M]

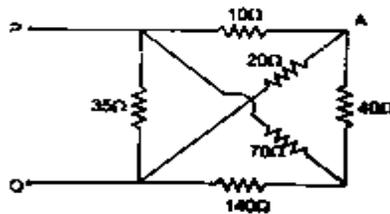

Figure

5. a) Draw the Parallel resonance circuit and derive the expression for resonant frequency [10M]

**OR**

b) The combined inductance of two coils connected in series is 0.6 H or 0.1 H depending on the relative directions of the current in the coils. If one of the coils when isolated has a self-inductance of 0.2H, calculate  
 i) the mutual inductance and  
 ii) the coupling coefficient [10M]

6. a) Explain about Z Parameters of a Two Port network [10M]

**OR**

b) Find the transmission parameters of the following two port network [10M].

